

KABE

Travel Master

USER MANUAL

KABE (Mercedes-Benz)

2023



EN

CONGRATULATIONS ON YOUR NEW MOTORHOME!

We congratulate you on your choice of motorhome.

This motorhome has been designed and built with great care. Its well-planned layouts and the attention to quality in every detail will ensure that it gives you great pleasure for very many years.

Before you start using your motorhome, we would like you to read the user manual carefully. This will ensure that you avoid unnecessary problems. Furthermore, the manual's instructions will help you get the most out of your motorhome.

Of course, certain items of equipment require quite detailed understanding. Your KABE distributor is more than willing to help should there be any uncertainty as regards technical specifications or correct use of the motorhome.

We wish you lots of happiness with your KABE Travel Master!

KABE AB

INDEX

PREFACE

ABOUT THE USER MANUAL.....	1-1
ATTACHED DOCUMENTATION	1-1

SAFETY INSTRUCTIONS

TRAFFIC SAFETY	2-1
ELECTRICAL SAFETY.....	2-1
VENTILATION	2-1
INTERIOR FITTINGS.....	2-1
FIRE SAFETY	2-1
BOTTLED GAS	2-1

USE

CHECK LISTS	3-2
BEFORE TRAVEL.....	3-2
WHEN PARKING.....	3-2
WHEN SETTING UP AT A CAMPING SITE	3-2
WINTER USE	3-3
WHEN FILLING WITH PETROL.....	3-3
LOCK/UNLOCK DOORS.....	3-4
LOCKING THE MOTORHOME.....	3-4
UNLOCKING THE MOTORHOME'S LIVING AREA.....	3-4
UNLOCKING FRONT DOORS.....	3-4
MAIN POWER SWITCH.....	3-5
CONTROL PANEL	3-5
OPERATING THE STEP.....	3-6
SEATS	3-7
PREPARING THE LOUNGE SEATING FOR TRAVEL	3-9
SEAT BELTS.....	3-9
TABLE POSITION WHILE TRAVELLING.....	3-9
ADJUSTING THE TABLE.....	3-10
MAKING UP DINETTE BEDS	3-11
SEATING WITH PULL-OUT EXTENSION	3-11
SEATING WITH PULL-OUT EXTENSION AND SIDE SOFA.....	3-12
SEATING WITH A SIDE SOFA AND A BED CUSHION.....	3-13
SEATING WITH A SIDE SOFA AND TWO BED CUSHIONS.....	3-14
SEATING WITH A SIDE SOFA AND THREE BED CUSHIONS	3-15
LOUNGE SEATING IN KABE VAN	3-16
DROP-DOWN CEILING BED	3-17
WINDSCREEN BLINDS.....	3-18
OPERATING AN ELECTRIC BLIND.....	3-18
KABE VAN: WINDSCREEN BLIND	3-19
LOADING	3-20
GENERAL.....	3-20
LOAD POSITIONING.....	3-20
GARAGE (LUGGAGE COMPARTMENT)	3-20
BOTTLED GAS SYSTEM.....	3-21
CHANGING GAS BOTTLES	3-21
USING THE LEAK INDICATOR	3-21
REFRIGERATOR.....	3-22
GAS HOB.....	3-24
USING THE GAS HOB	3-24
TURNING OFF THE GAS HOB	3-24
MICROWAVE OVEN	3-25
HEATING SYSTEM	3-26
STARTING THE HEATING SYSTEM	3-27
SETTING THE DESIRED TEMPERATURE.....	3-28

HOT WATER.....	3-28
HEATING USING A 230 V SUPPLY.....	3-29
HEATING USING BOTTLED GAS.....	3-30
SETTING FLOOR HEATING.....	3-31
HEATING THE LIVING AREA DURING TRAVEL.....	3-32
WINTER CONNECTION (MOUNTAIN CONNECTION).....	3-33
WATER/WASTE WATER SYSTEMS	3-34
FILLING WITH FRESH WATER.....	3-34
DRAINING THE FRESH WATER SYSTEM.....	3-35
CLEANING THE FRESH WATER TANK.....	3-35
DRAINING THE GREY WATER TANK.....	3-36
CLEANING THE GREY WATER TANK.....	3-37
USING WATER TAPS.....	3-38
USING THE WASTE WATER SYSTEM.....	3-38
USING THE SHOWER.....	3-38
CINDERELLA MOTION TOILET.....	3-39
PREPARING THE TOILET FOR USE.....	3-39
USING THE TOILET.....	3-39
EMPTYING THE TOILET.....	3-39
THETFORD C263 TOILET.....	3-40
PREPARING THE TOILET FOR USE.....	3-40
USING THE TOILET.....	3-40
EMPTYING THE TOILET.....	3-41
BATTERY CHARGING.....	3-42
CHECKING BATTERY CHARGE.....	3-42
CHARGING BATTERIES.....	3-42
SILENT MODE.....	3-42
AWNING.....	3-43

DESCRIPTIONS

DESCRIPTIONS – VEHICLE.....	4-2
CHASSIS.....	4-2
TOW HOOK.....	4-2
RUNNING LIGHTS.....	4-2
WHEELS.....	4-3
SNOW CHAINS.....	4-3
SUPPORT LEGS.....	4-4
HYDRAULIC SUPPORT LEGS.....	4-4
BOTTLED GAS SYSTEM.....	4-5
BOTTLED GAS.....	4-5
THE BOTTLED GAS SYSTEM.....	4-5
GAS BOTTLES.....	4-6
HOSE BREAK VALVE.....	4-7
GAS PRESSURE REGULATOR.....	4-7
LEAK INDICATOR.....	4-8
CHECKING THE BOTTLED GAS SYSTEM.....	4-9
GAS PRESSURE AND TEMPERATURE.....	4-9
BOTTLED GAS CONSUMPTION.....	4-9
REFRIGERATOR.....	4-10
TURNING OFF THE REFRIGERATOR.....	4-10
TRAVEL CATCH.....	4-10
ADAPTING THE REFRIGERATOR'S VENTILATION.....	4-11
FAN BEHIND THE REFRIGERATOR.....	4-11
GENERAL REFRIGERATOR INSTRUCTIONS.....	4-12
HEATING SYSTEM.....	4-14
GENERAL ABOUT THE HEATING SYSTEM.....	4-14
THE BOILER.....	4-16
EXPANSION TANK.....	4-18
HEATING SYSTEM FLUID.....	4-19
CONVECTOR SYSTEM.....	4-19
HEATING LOOPS IN THE FLOOR.....	4-20
ZONE HEAT.....	4-21
WINDSCREEN HEATING.....	4-21
WINTER CONNECTION (MOUNTAIN CONNECTION).....	4-21

VENTILATION	4-22
FIXED VENTILATION	4-22
ROOF HATCHES	4-22
KITCHEN VENTILATION	4-22
CONDENSATION	4-22
AIRVENT.....	4-23
AIR CONDITIONING (AC).....	4-23
WATER/WASTE WATER SYSTEMS	4-24
FRESH WATER SYSTEM	4-24
GREY WATER SYSTEM	4-28
RISK OF FREEZING.....	4-30
TOILETS.....	4-31
CINDERELLA MOTION INCINERATING TOILET	4-31
THETFORD C263 TOILET	4-32
ELECTRICAL SYSTEM	4-33
THE 230 V AC ELECTRICAL SYSTEM.....	4-33
12 V TO 230 V INVERTER.....	4-34
MAIN POWER SWITCH, 12 V SYSTEM	4-35
ALARM ON ENGINE START.....	4-35
GENERAL TECHNICAL DESCRIPTION OF THE LIVING AREA'S 12 V SYSTEM	4-36
CONTROL PANEL	4-37
BATTERIES AND BATTERY CHARGING.....	4-44
LIGHTS	4-47
OUTSIDE LIGHT WITH MOTION SENSORS	4-47
FUSES	4-48
CIRCUIT DIAGRAMS	4-59
PANELS WITH SOLAR CELLS	4-62
DESCRIPTIONS – ANTENNA SYSTEM	4-63
KABE SMART D REMOTE.....	4-64
INTRODUCTION.....	4-64
CONDITIONS	4-64
CONNECTING TO THE VEHICLE	4-64
CONNECTING SEVERAL MOBILE TELEPHONES	4-64
ON A CHANGE IN VEHICLE OWNERSHIP.....	4-64
START MENU.....	4-65
HEATING MENU	4-66
AC / AIRVENT MENU	4-67
MAINTENANCE	
MAINTENANCE SCHEDULES	5-2
WEEKLY MAINTENANCE	5-2
MONTHLY MAINTENANCE	5-2
YEARLY MAINTENANCE.....	5-2
CLEANING.....	5-3
WASHING THE EXTERIOR	5-3
CLEANING THE INTERIOR.....	5-5
CUTTING BOARDS	5-5
LONG-TERM STORAGE	5-6
PRECAUTIONS BEFORE LONG-TERM STORAGE	5-6
PRECAUTIONS DURING LONG-TERM STORAGE.....	5-7
PRECAUTIONS BEFORE USING AFTER LONG-TERM STORAGE.....	5-7
BLEEDING THE CONVECTOR SYSTEM.....	5-8
WORKTOP DRAWERS.....	5-9
DRAWER ADJUSTMENT	5-9
DRAWER REMOVAL	5-9
DRAWER FITTING	5-9
WORKTOP PULL-OUT BASKETS	5-10
PULL-OUT REMOVAL	5-10
PULL-OUT FITTING	5-10
FRONT PANEL ADJUSTMENT	5-10
CUPBOARD DOOR ADJUSTMENT	5-11
CROCKERY CUPBOARD DOOR.....	5-11
OVERHEAD CUPBOARD DOOR.....	5-11

PREFACE

ABOUT THE USER MANUAL

This user manual is for the living area of the 2023 KABE Travel Master (Mercedes-Benz).

The information in this manual is divided into four sections:

- Safety instructions
- Use
- Descriptions
- Maintenance.

The “Safety instructions” section of this manual gives succinct information on avoiding risks.

The “Use” section is intended for reference. It gives easy-to-follow, step-by-step instructions on the use of various pieces of equipment.

The “Use” section also provides sufficient information for the correct use of the motorhome’s living area. However, for full details and in-depth understanding, the “Descriptions” section must also be read.

The “Descriptions” section is designed to:

- give information about the motorhome and its parts so that users understand how these work and interact with each other.
- identify and name parts so that use and maintenance in accordance with the manual’s instructions is facilitated.
- bring attention to risks and remarks that are important for the correct use of the motorhome.
- complement the instructions in the “Use” section by adding in-depth information and instructions.

The texts and illustrations in these sections are primarily intended to be descriptive (not instructive).

The “Maintenance” section gives instructions for the correct maintenance of the motorhome. Maintenance includes both scheduled checks and other measures.

Note that this user manual relates only to the motorhome’s living area.

For instructions regarding the use and maintenance of the vehicle part of the motorhome, KABE refers you to the user manual provided by the vehicle’s manufacturer.

Illustrations in the present manual may relate to optional equipment or non-standard variants.

ATTACHED DOCUMENTATION

Documents from the manufacturers of the appliances and equipment in the motorhome are appended to this manual. To understand the correct operation, use and maintenance of all the equipment, it is important to also read this documentation.

Certain information is given in both KABE’s user manual and the equipment manufacturers’ documentation. In the event of any discrepancies between information or instructions in these, the manufacturers’ documentation has precedence.

SAFETY INSTRUCTIONS

TRAFFIC SAFETY

Ensure that the motorhome is correctly loaded. Loads must be evenly distributed and secured in the motorhome.

Heavy loads must be placed low down. Only lightweight equipment is to be kept in overhead cupboards and similar storage facilities.

There must be no loose equipment that can harm passengers.

Check the weight of loads and ensure that the vehicle's maximum permitted weight is not exceeded.

Distribute loads in the motorhome so that permitted axle loads are not exceeded. The permitted load for each axle is stated on a plate in the engine bay.

Motorhomes with bicycle carriers:

Ensure that the bicycle carrier is secured in the "drive" position and that the bicycles are correctly attached and secure.

Before travel:

- close all exterior doors.
- ensure that the motorhome's steps are retracted.
- ensure that the support legs have been fully wound up.
- close interior cupboard doors and drawers.
- ensure that the refrigerator door is secured.

ELECTRICAL SAFETY

To connect 230 V AC, use 3 x 2.5 mm² earthed cable approved for outdoor use and power loads of 3,600 W.

Connect the power cable only to an earthed socket.

Ensure that the power cable is placed out of the way of all danger.

Damaged power cables must be replaced.

When replacing batteries, use the correct type of battery for the motorhome and its equipment. Risk of injury and overheating.

VENTILATION

Ensure that all ventilation channels are unobstructed.

Roof hatches and ventilators must be unobstructed. Ensure that nothing impedes ventilation. Ventilation via roof hatches and valves must be kept open after snowfalls.

INTERIOR FITTINGS

Certain models have a ceiling-mounted bed. Use the bed's fall guard.

Certain models have a step.

The step's maximum permitted load is 100 kg.

FIRE SAFETY

Familiarise yourself with the firefighting equipment at your camping site.

Powder extinguishers are recommended for fires in motorhomes.

If the door is obstructed/jammed, openable windows can be used as emergency exits. Ensure that openable windows do not get obstructed/jammed.

Ensure that the motorhome's fire alarm is working. Change batteries as necessary or once a year. Test the fire alarm once a week (hold the button down until the alarm goes off).

In the event of fire:

- Disconnect the 230 V electricity supply.
- Close the gas bottle's master valve in the gas bottle locker.
- If possible, move gas bottles to a safe place. They are pressure vessels that must not be exposed to overly high temperatures. If the gas bottles cannot safely be moved, evacuate the vicinity of the motorhome.
- Tell the firefighters where the gas bottles are.

BOTTLED GAS

Bottled gas is highly flammable. It must be treated with respect.

When changing gas bottles, ensure that the area is free from naked flames and glowing or hot objects that may ignite the gas.

If any gas appliance is lit, driving into a petrol station is prohibited. Ensure that the boiler and refrigerator are turned off. Turning off all gas appliances before driving into a petrol station is the driver's responsibility.

In garages, ferries or other enclosed areas, gas appliances must be turned off and the master valve of each bottle must be closed.

When the motorhome is not being used, close the master valve of each gas bottle.

When changing gas bottles, use the leak tester to test the system for leaks. If there is any suspicion of a leak, contact a professional.

Every year, a professional must test the gas system for leaks. Repairs to the gas system must be carried out by a professional.

Only bottled gas of the types stated in this manual (i.e. standard bottled gas) may be used for the motorhome's gas appliances.

USE

Use

CHECK LISTS

BEFORE TRAVEL

- Loads:
 - Avoid overloading. Ensure that the motorhome's total permitted weight is not exceeded.
 - Loads must be correctly distributed (low centre of gravity, even distribution between the right and left sides of the motorhome).
 - In the living area, there must be no loose objects that could present a danger to passengers.
 - Loads must be secured or positioned so that there is no risk of them shifting, working loose or causing damage.
- TV antenna in its bottom position.
- Refrigerator door secured. Interior doors, drawers and cutting boards closed/secured.
- Roof hatches and windows closed. Roof hatch blackout curtains must be raised.
- Shower door or folding panel secured.
- The toilet door must be closed throughout travel.
Certain layouts have a door that closes across the centre aisle. Throughout travel, the door must be closed to the toilet.
- Use the kitchen sink and hand basin plugs (prevents a drain smell entering the motorhome while travelling).
- Swivel seats secured in the direction of travel.
- Step retracted.
- Doors closed.
- Main valve of each gas bottle closed.
- Power and TV cables disconnected.
- No snow, ice or other loose object on the roof.
- Support legs raised. (Motorhomes with support legs fitted.)
- Any items of optional equipment (bicycle carriers, air conditioning, etc.) ready for travel.

WHEN PARKING

- When you have parked: Open and close the driver's door.

The vehicle part of the motorhome is programmed to have a few functions still operating during short stops. By opening and closing the door, you confirm that the vehicle is parked. Side lights go out and a few other functions shut down.

When the driver/passenger door is open, the associated step light comes on. The step light goes out after a while, but can come on again at any time the driver or passenger door is open.

WHEN SETTING UP AT A CAMPING SITE

- Ensure there is easy access for loading/unloading and filling the water tank.
- Park the motorhome so that it is level (i.e. not tilting in any direction).
- Stabilise the motorhome by deploying the support legs. (Motorhomes with support legs fitted.)
- Where possible/required, connect a 230 V supply.
- Certain motorhomes have a DEFA alarm:
The alarm is activated when the motorhome is locked.

If you want to lock the motorhome when you are inside, the alarm's motion sensors must be deactivated. (The motorhome's doors are alarmed.)

To deactivate the alarm's motion sensors, use the button next to the alarm LED on the device's window module. Hold the button down until the LED goes out. Then use the remote control (on the key) to lock the motorhome.

The alarm's motion sensors are deactivated until the motorhome's ignition is switched on. This resets the alarm to normal function.

See also the instructions from the alarm's manufacturer, DEFA.

WINTER USE

Before winter use

- To protect locks from freezing, lubricate them with a suitable agent.
- Ensure that the glycol level in the heating system is correct.
- Ensure that the battery is fully charged.
- As a safeguard, carry two bottles of gas (not bottles made of composite materials).
- Take extra fuses for the motorhome and external power supply posts.
- Fit the winter hatch to the refrigerator's ventilation grille.
- If using the hand brake, remember the risk that it may freeze solid.
- Before starting up the heating, clear snow and ice from roof hatches and valves (so that the motorhome's ventilation works).
- Do not shovel snow into heaps around the motorhome. Ensure that roof hatches and roof valves are not snow covered. There is a risk of safety ventilation being restricted.

During winter use

- If the motorhome is cold, check:
 - that the power cable is connected.
 - that the 230 V fuse in the electricity supply post is OK.
 - the circuit breaker for the motorhome's boiler.
 - that the neighbours have power.
 - that the level in the expansion tank is correct.
- If the refrigerator does not get cold, start it in bottled gas mode instead of 230 V.
- Fill up with water and, before filling the fresh water system, ensure that all taps and drain valves are in the closed position.
- Ensure that the chimney is free from snow and ice. The chimney extension must be fitted when using the motorhome in the winter (only models with roof-mounted chimneys).
- Ensure that the fixed safety ventilation system is not obstructed by snow or anything else.

After winter use

- Drain the water system and the grey water tank (see the separate instructions). Put all taps into the OPEN position (halfway between hot and cold).
- Drain hoses, taps and water heaters. Drain the flushing water from the toilet. Thoroughly check that water taps and shower hoses are empty.
- If a water purifier (option) has been fitted, remove it.
- Empty the toilet's waste tank.
- Remove foodstuffs and personal items that may be harmed by low temperatures.
- Check that the settings of the immersion heater, thermostat and circulation pump are correct.
- Check that all roof hatches are closed.

WHEN FILLING WITH PETROL

- Ensure that all gas appliances are turned off.
If any gas flame is lit, driving into a petrol station is prohibited. Fire risk.
- Fill until the pump turns off automatically.
Adding any more may result in: fuel running out of the breather valve; and, damage due to overfilling.



LOCKING/UNLOCKING DOORS

The motorhome's central locking system for access and load doors is remotely controlled via the vehicle's key.

- A: Locks access and load doors.
- B: Unlocks driver and front passenger doors.
- C: Unlocks living area access and load doors.

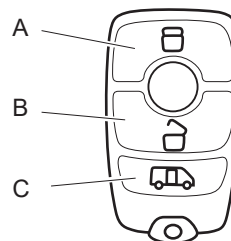

LOCKING THE MOTORHOME

To lock the motorhome's access and load doors, press key button A.

Use

UNLOCKING THE MOTORHOME'S LIVING AREA

When the motorhome is locked:

Press key button C to unlock load doors and living area access.

The driver and passenger front doors are not affected (they remain locked).

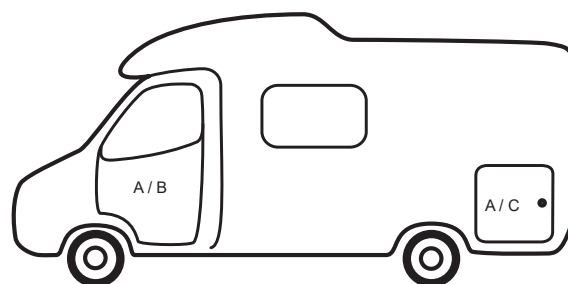

UNLOCKING FRONT DOORS

When the motorhome is locked:

Press key button B to unlock driver and front passenger doors.

Living area access and the load doors are not affected (they remain locked).

To confirm that the doors should be unlocked, open one of the motorhome's driver or front passenger doors.

If you do not open one of these front doors, the motorhome interprets this as an accidental unlocking.

The motorhome will then automatically lock all access and load doors (function A).

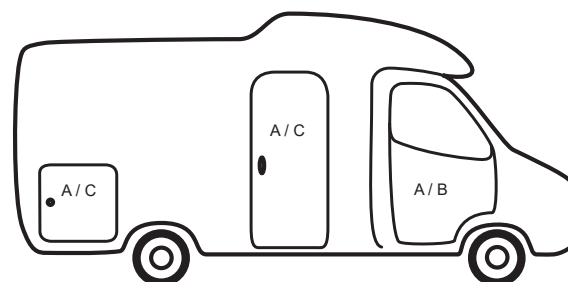

Important!

There is a risk of being locked out if function A is activated automatically.

For further details, please refer to the vehicle manufacturer's user manual.

MAIN POWER SWITCH

The living area's 12 V system has a main power switch with a key.

When the motorhome is not being used, turn the main power switch off.



CONTROL PANEL

The control panel's functions are described in section 4, "Descriptions".

Electrical system
(Standby)
ON-OFF



Use

OPERATING THE STEP

Applies only to models that have a retractable step.

Use the switch just inside the door to operate the step.

The step must only be used in the completely extended position.

Before travel, use the switch to retract the step. Ensure that the step is fully retracted and “traffic-safe”.

The step is connected so that it automatically retracts when the motorhome’s engine starts. This also means that the step is locked in the retracted position when the engine is running.

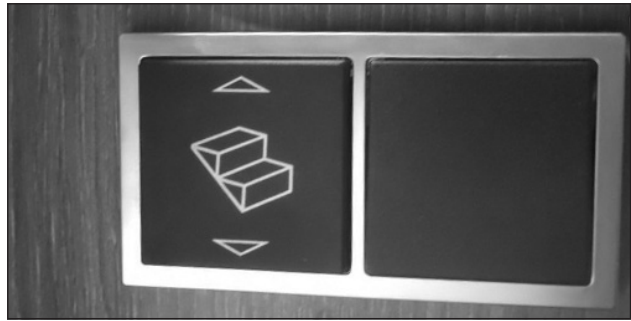

Use



WARNING!

Before travel, ensure that the step is retracted.

Throughout travel, the step must be retracted so that it does not present a danger to other road users and pedestrians.

NB!

The step must only be used in the completely extended position.

Loading it when only partly extended can result in damage to the step’s parts.

SEATS

The motorhome's cab seats can swivel.

Throughout travel, the driver's seat and the passenger's seat must be locked facing forward.

Fully integrated motorhomes



KABE Van

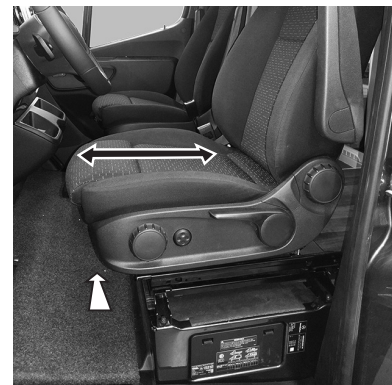

Use

Use

Fully integrated motorhomes



KABE Van



PREPARING THE LOUNGE SEATING FOR TRAVEL

SEAT BELTS

Certain models have a retractable mount for seat belts.

Throughout travel, the seat belt mount must be in the travel position. The correct travel position is indicated by a mark (A).



Travel

Camping

To adjust the mount, press the button while also adjusting the height of the mount. The button is concealed in the cushion.

The seat belt mount has a strong spring. Pushing it down requires quite a lot of force.



Throughout travel, the mark (A) must be level with the edge (B) of the pillar's outer section.



TABLE POSITION WHILE TRAVELLING

Throughout travel, the table must be in the “drive” position.

Certain models have a fixed table that can be folded up. Throughout travel, the table must be in the bottom position and folded so the top faces forward. See picture.

Certain models have a wall-hung table. Throughout travel, the table must be in the drive position. Secure the table in the drive position so that it does not present a risk if the vehicle has to brake sharply or if there is a traffic accident.



Use

ADJUSTING THE TABLE

The tabletop's position can be adjusted a few centimetres.

- Pull the catch downward.
- Adjust the tabletop's position.
- Lock the tabletop's position by pushing the catch upward.

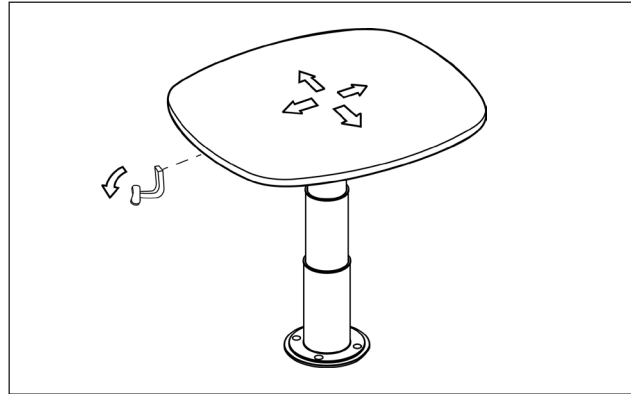

Use

The table can be rotated

- Twist the table.

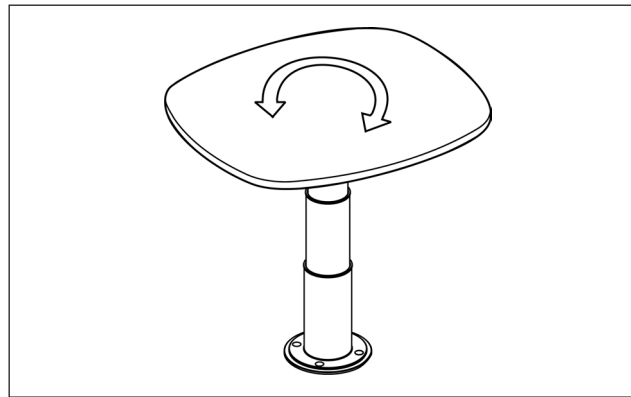

The table's height can be adjusted

- Tilt the lever.
- Exerting pressure directly over the table's leg, push the table downward.
- Lock the table's height via the lever. There are three table height settings.

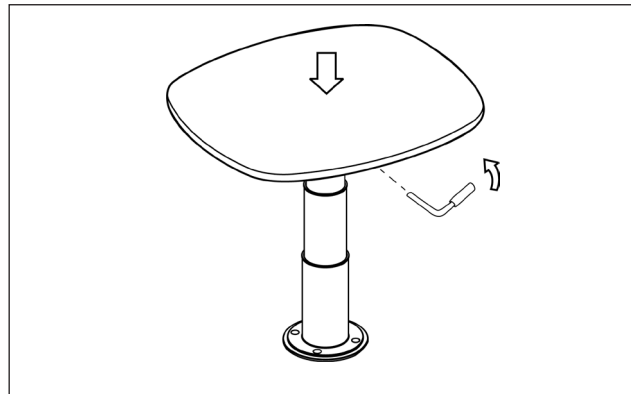

The table can be angled.

- Pull the spring-loaded pin outward.
- Angle the tabletop.

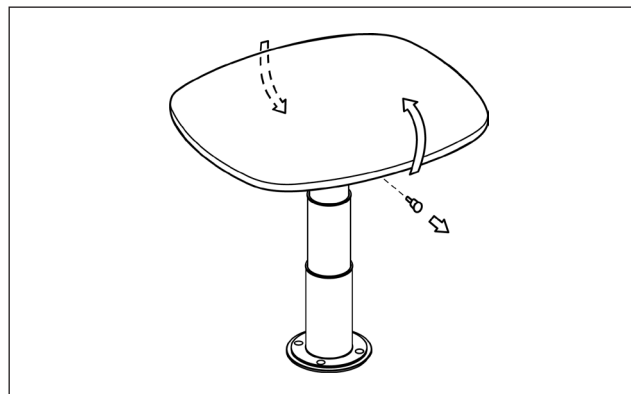

MAKING UP DINETTE BEDS

Depending on motorhome layout, there are different types of lounge seating. Make up lounge seating beds as per one of the following descriptions.

SEATING WITH PULL-OUT EXTENSION.

In addition to the existing sofa, bed making requires the following elements:

- A Bedboard with support legs.
- B Bed cushion.
- C Bed cushion.

- 1 Lower the table.
- 2 Pull out the sofa extension.
- 3 Rest the bedboard (A) so that it is supported by its own legs and the sofa extension.
- 4 Position the cushions as shown in the figure below.

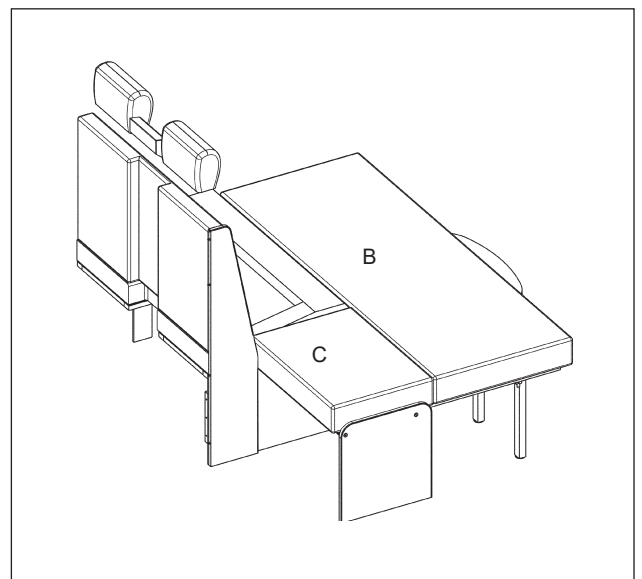
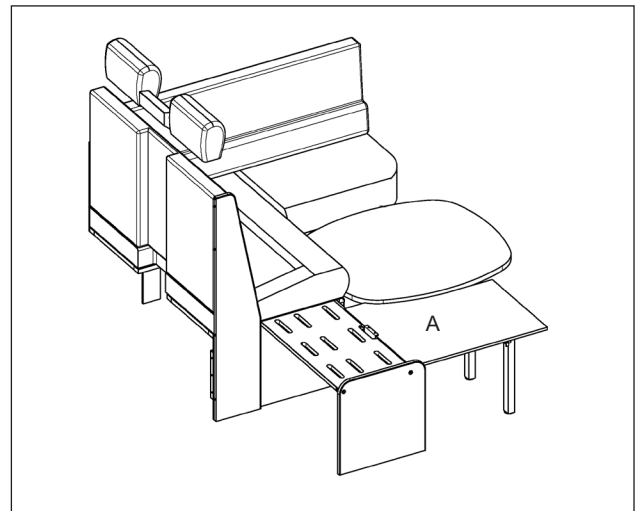
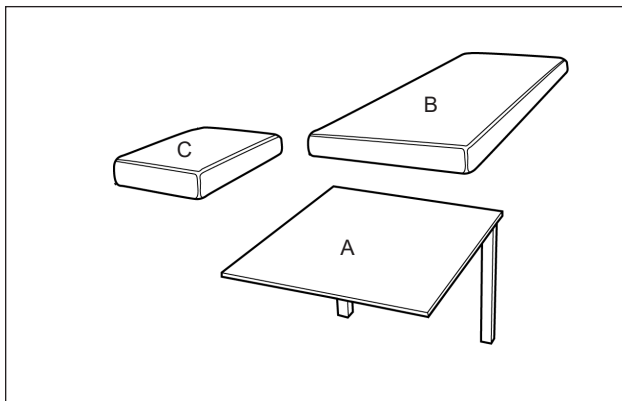
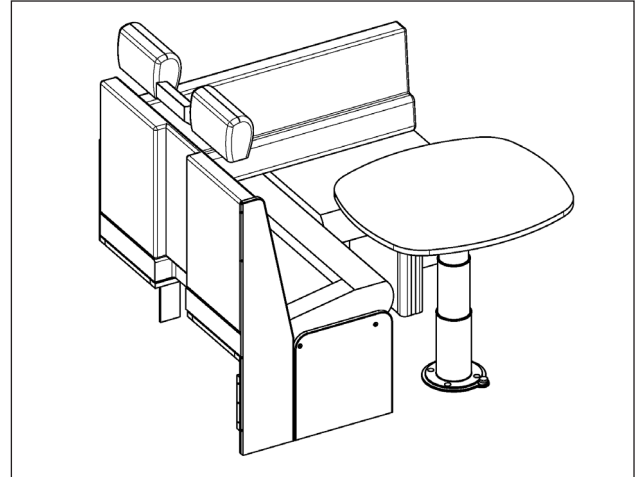

SEATING WITH PULL-OUT EXTENSION AND SIDE SOFA

In addition to the existing sofas, making up lounge seating beds requires the following elements:

- B Bed cushion.
- C Bed cushion.
- S Support legs.

- 1 Lower and adjust the table do that it rests on the sofa's edge.
- 2 Position the bedboard (A) between the seat and the table. Fit the support legs (S) so that they support the bedboard.
The number of support legs may vary between different models.

When travelling, stow the bedboard (A) next to the side seating's back rest.

- 3 Pull out the sofa extension.
- 4 Position the cushions as shown in the figure.

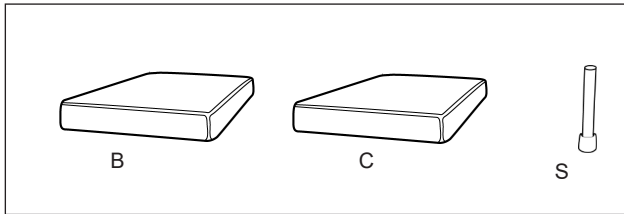
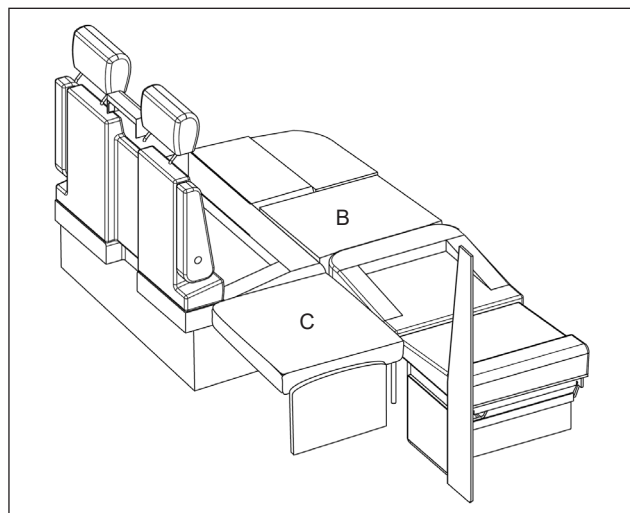
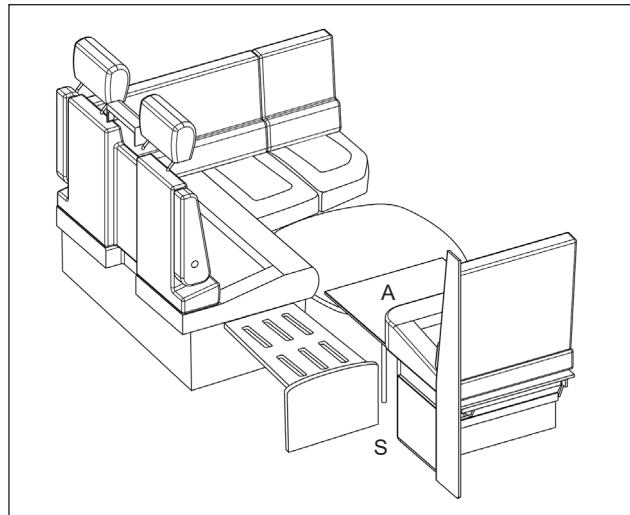
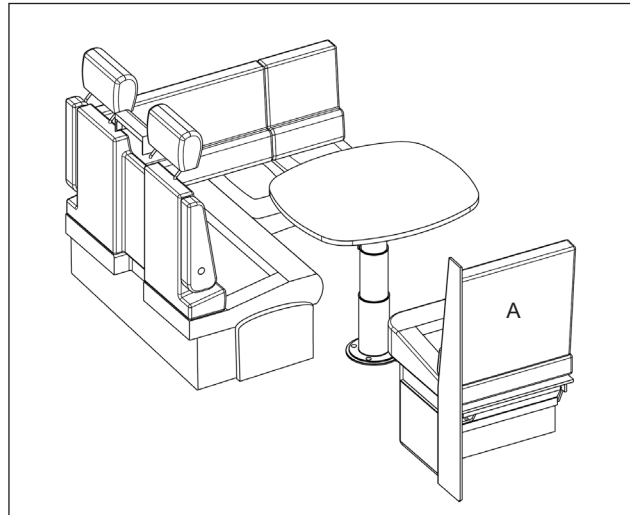

SEATING WITH A SIDE SOFA AND A BED CUSHION

In addition to the existing sofas, making up lounge seating beds requires the following elements:

- B Bed cushion.
- S Support legs.

- 1 Lower and adjust the table do that it rests on the sofa's edge.
- 2 Position the bedboard (A) between the seat and the table. Fit the support legs (S) so that they support the bedboard.
The number of support legs may vary between different models.
When travelling, stow the bedboard (A) next to the side seating's back rest.
- 3 Position the cushions as shown in the figure.

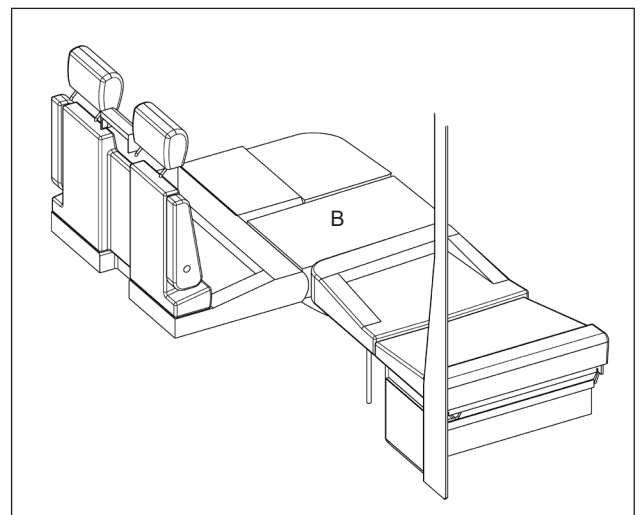
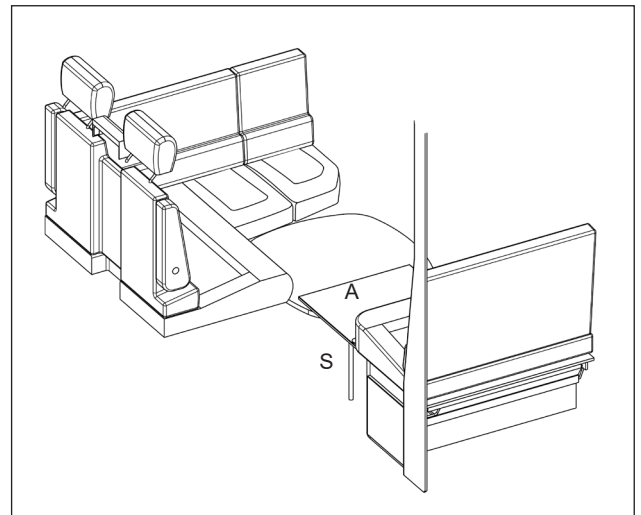
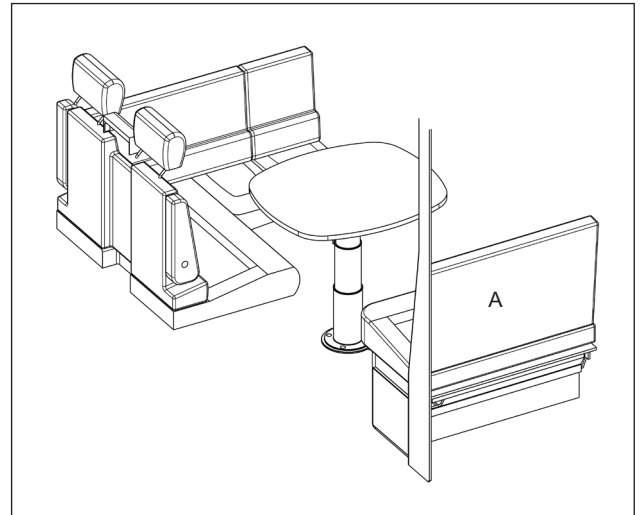
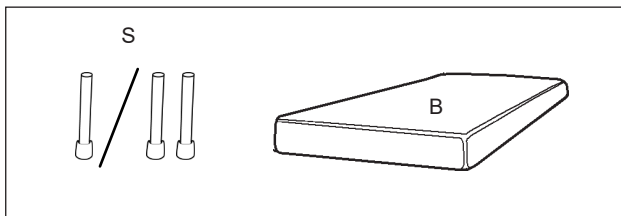

SEATING WITH A SIDE SOFA AND TWO BED CUSHIONS

In addition to the existing sofas, making up lounge seating beds requires the following elements:

- B Bed cushion.
- C Bed cushion.
- S Support legs.

- 1 Lower and adjust the table do that it rests on the sofa's edge.
 - 2 Position the bedboard (A) between the seat and the table. Fit the support legs (S) so that they support the bedboard.
- The number of support legs may vary between different models.

When travelling, stow the bedboard (A) next to the side seating's back rest.

- 3 Position the cushions as shown in the figure.

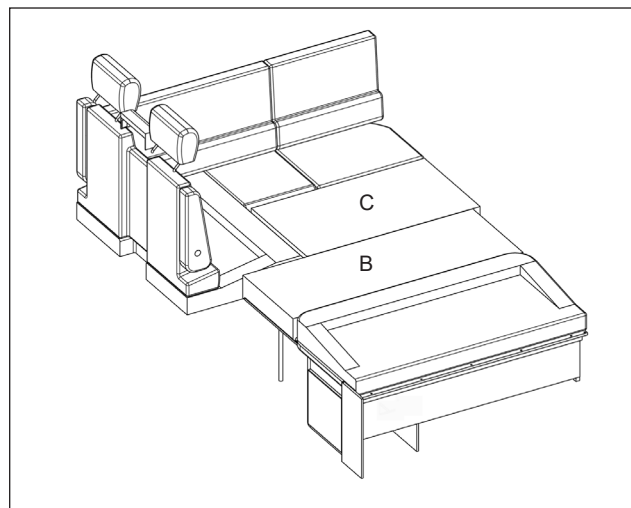
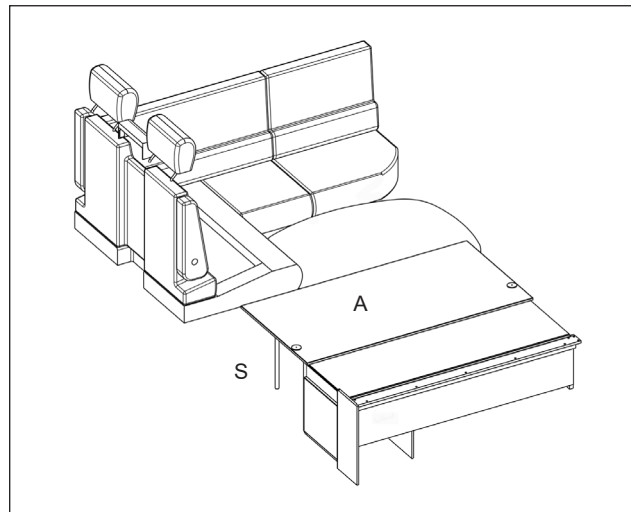
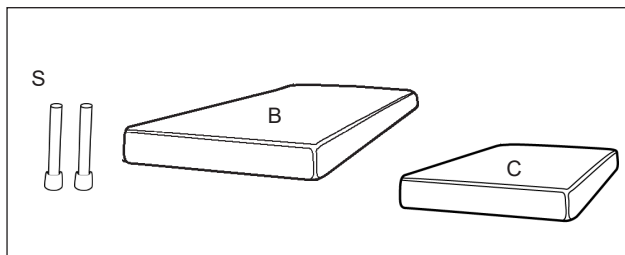
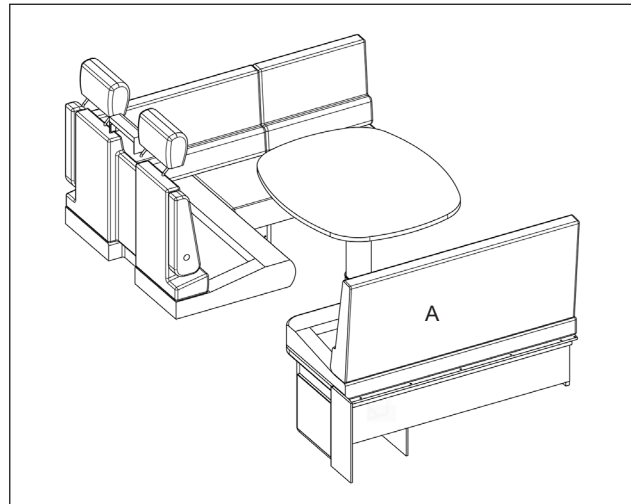

SEATING WITH A SIDE SOFA AND THREE BED CUSHIONS

In addition to the existing sofas, making up lounge seating beds requires the following elements:

- B Bed cushion.
- C Bed cushion.
- D Bed cushion.
- S Support legs.

- 1 Lower and adjust the table do that it rests on the sofa's edge.
- 2 Position the bedboard (A) between the seat and the table. Fit the support legs (S) so that they support the bedboard.
The number of support legs may vary between different models.
When travelling, stow the bedboard (A) next to the side seating's back rest.
- 3 Position the cushions as shown in the figure.

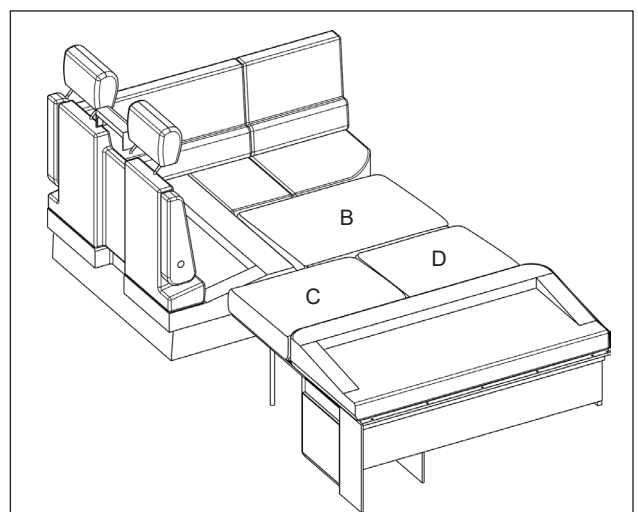
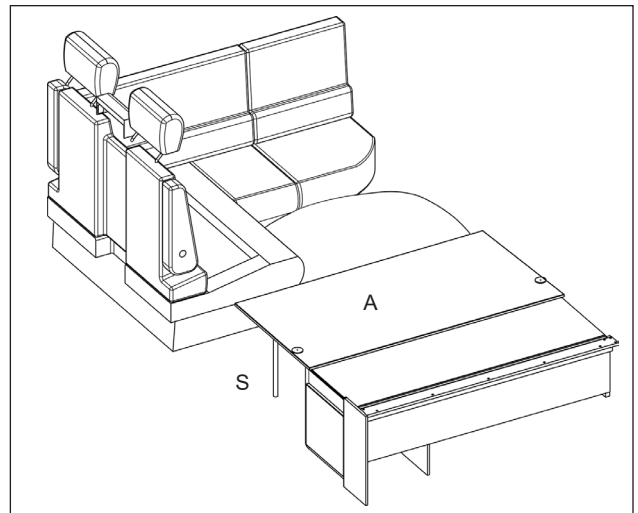
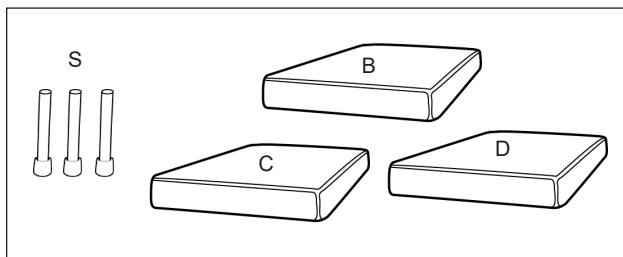
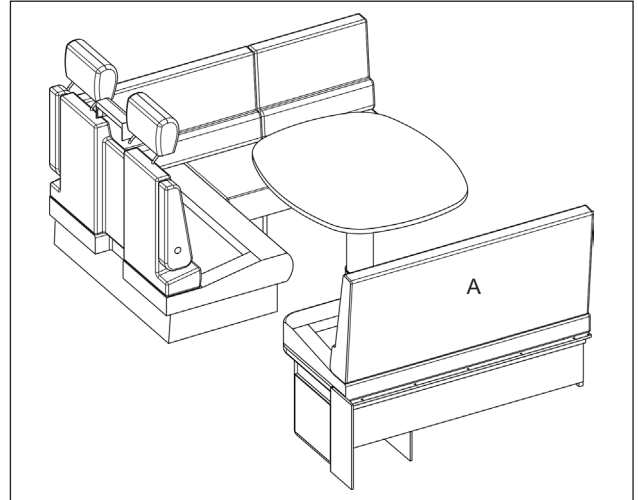

LOUNGE SEATING IN KABE VAN

In addition to the existing sofa, bed making requires the following elements:

- A Bedboard with support legs.
- B Bed cushion.

- 1 Lower the table.
- 2 Using the bedboard (A), extend the table.
- 3 Position the cushions (B) as shown in the figure below.

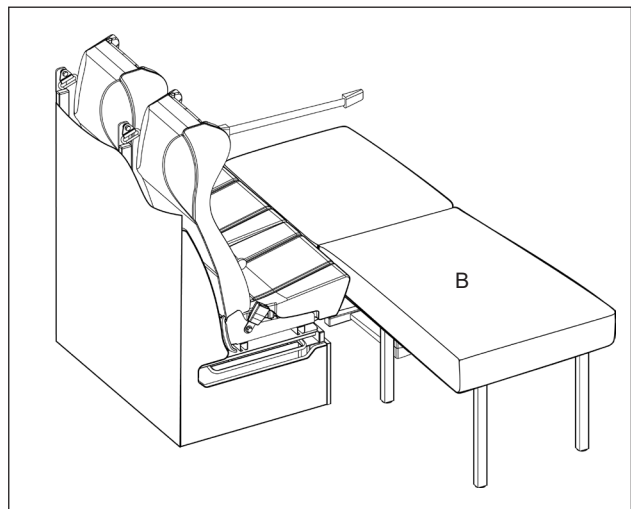
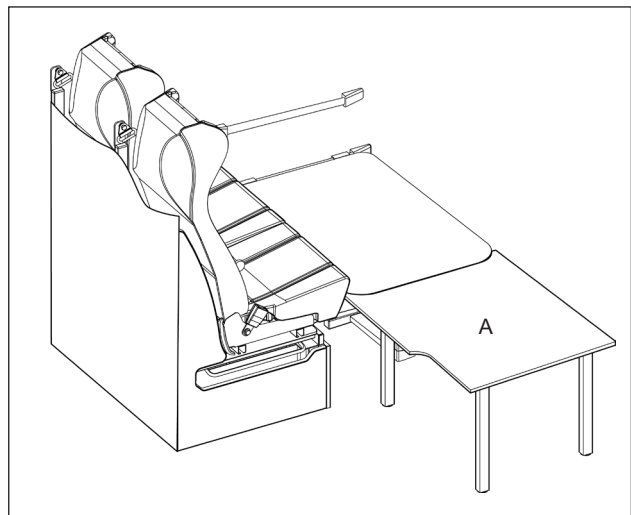
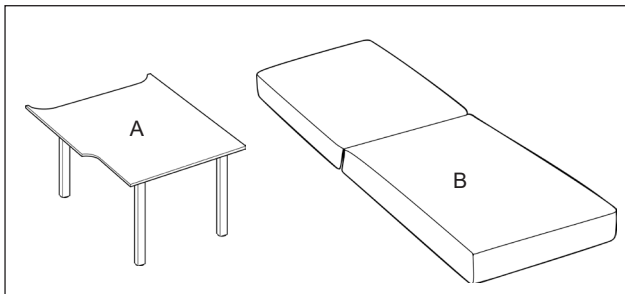
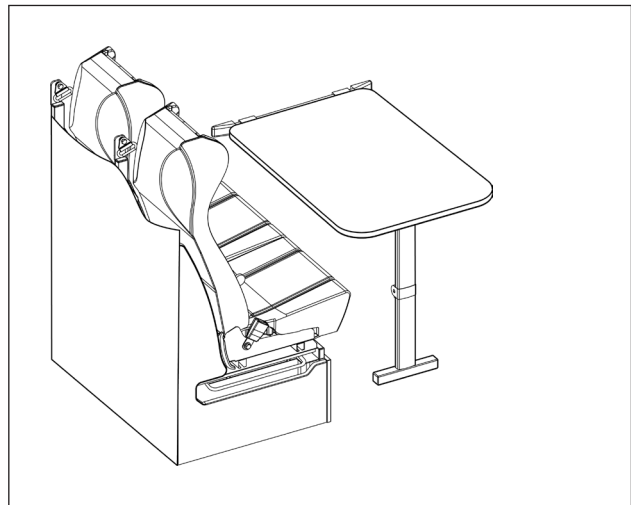

DROP-DOWN CEILING BED

Certain models have a drop-down bed above the motorhome's seats.

Throughout travel, the bed must be raised in its upper end position.

When the bed is to be used, it must be lowered to its lower end position. The maximum permitted load is 200 kg. The bed must not be loaded while it is being raised or lowered.

Certain models have a step.

The step's maximum permitted load is 100 kg.

Electrically operated beds are controlled from the motorhome's control panel (A).



To operate the bed:

- 1 Fully fold the seats' back rests so that the bed cannot rest on the seats.
- 2 To protect the seating's back cushion, rest it horizontally.
- 3 Lower the bed to the end position.
- 4 Use the bed's fall guard. Ensure that the fall guard's straps are long enough for the bed not to be held by the straps.
- 5 Before travel: Raise the bed to its upper end position. Any loads must be stowed somewhere else. A load in/on the bed can prevent it reaching the end position.

Manual bed (not motor operated):

In its raised position, ensure that the bed is secured by both locks.

NB!

Carefully check there is nothing that is in the way of, or can be damaged by, the bed.
If the bed's motors seem to be running slowly or unevenly, stop and check the cause.



WARNING!

So that there is no risk of injury, the bed must not be raised or lowered while there is anyone in, under or near the bed.

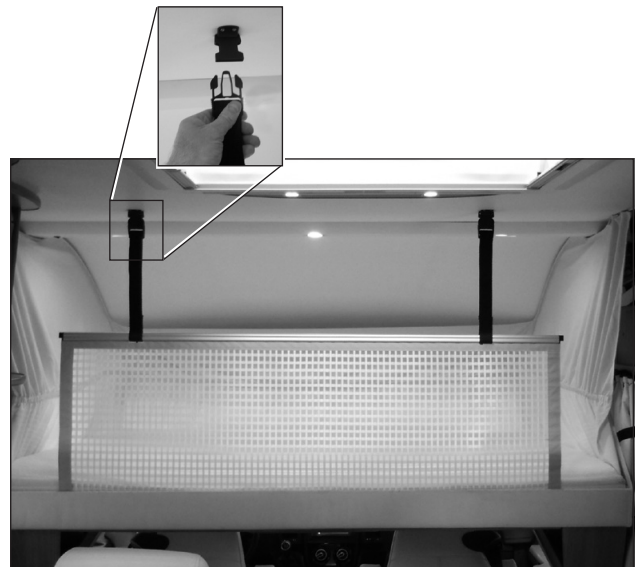

Use

WINDSCREEN BLINDS

All KABE motorhomes have blinds so that the front part of the motorhome can be darkened. These blinds must not be used while travelling.

- Certain models have manually operated blinds.
- Certain models have an electrically operated blind. See the information below.

OPERATING AN ELECTRIC BLIND

(Certain models only.)

Throughout travel, motorhome blinds must be fully raised.

Electric blinds are operated from the motorhome's control panel.

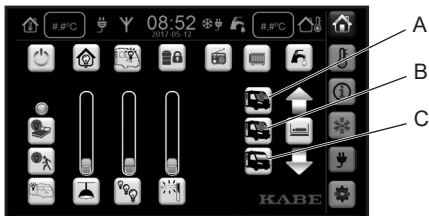

- A Open position.
- B Blackout.
- C Privacy position. Preset position that covers the lower part of the windscreen.

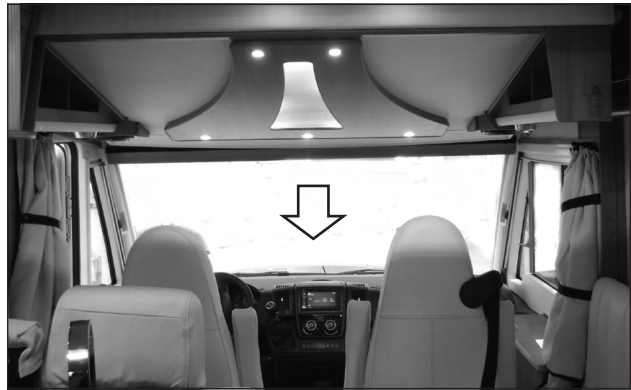

Emergency operation

If there is a problem with your motorhome's electric blind, try the following emergency measures.

- 1 Switch off the motorhome's electrical system.
Restart the electrical system.
Try to operate electrically.
- 2 A) Unscrew the two grilles above the windscreen.
B) If there are no grilles, remove the panel (above the windscreen) that hides the blind's two motors. The panel is secured by screws.
- 3 Next to each motor, there is an arrangement for manually winding up the blind using an Allen key. One of the motors drives the upper part of the blind. The other drives the blind's lower part.

KABE VAN: WINDSCREEN BLIND

Relates to KABE Van. (Certain models only.)

Throughout travel, the motorhome's blind must be secured in the raised position.

Deploying the windscreen blind

- 1 Release the blind's Velcro strip (A).
- 2 Lower the blind by pressing the button (B).
- 3 Insert the bottom of the blind into the holder (C).
- 4 Fit the lower guide rod (D) into the holder (E) on the dashboard.
- 5 Repeat points 1 – 4 for the other half of the blind.
- 6 Swing the upper guide rods (F) upward and join them. Insert the joined upper guide rod into the holder (hidden behind the edge).
- 7 Carefully pull the halves of the blinds out. Angle the edges of the halves of the blinds so they fit in the holders and can meet in the middle of the windscreen.

Stowing the windscreen blind

- 1 Pull the halves of the blind apart. Ensure that the blind folds up neatly and correctly.
- 2 Undo the upper and lower guide pins (F and D).
- 3 Swing the blind up behind the edge. Ensure that it hooks securely in the holder (button B).
- 4 So that there is no risk of the blind coming loose during travel, use the Velcro strip (A) to secure it.

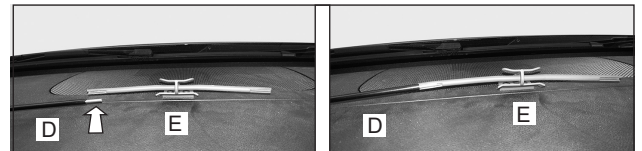
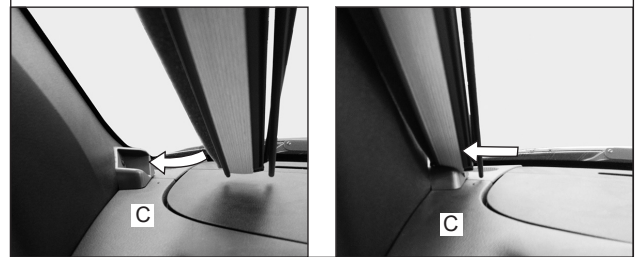
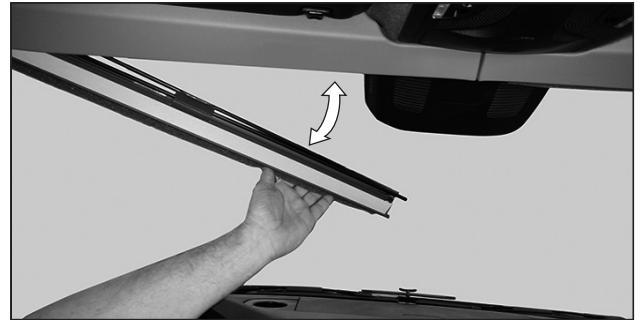
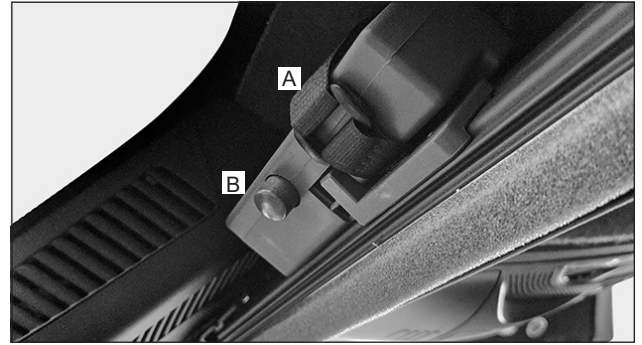

Use

LOADING

GENERAL

Avoid overloading. Ensure that the motorhome's total permitted weight is not exceeded.

LOAD POSITIONING

Loads must be correctly distributed:

- Low centre of gravity.
Light loads in overhead cupboards. Heavy loads near the floor.
- Evenly distributed between the right and left sides of the motorhome.
- Appropriately distributed so that permitted axle loads are not exceeded. Permitted axle loads are stated on a plate in the engine bay.

In the living area, there must be no loose objects that could present a danger to passengers during travel. Loads must be secured or positioned so that there is no risk of them shifting, working loose or causing damage.



Use

GARAGE (LUGGAGE COMPARTMENT)

When loading, ensure that the door's frame is not overloaded and does not risk being deformed. Ensure that loads are supported by the garage floor (not by the door's frame).

Secure loads before travel.



NB!

Risk of damaging the door's frame.
Avoid overloading the door's frame.

BOTTLED GAS SYSTEM

CHANGING GAS BOTTLES

Change gas bottles as follows:

- 1 Turn off all gas appliances in the motorhome.
- 2 Close the gas bottle's master valve.
- 3 Unscrew the hose from the gas bottle.
The connector has a left-hand thread and screws off in a clockwise direction.
Certain models have a hose break valve between hose and bottle.
Leave the hose break valve on the hose.
- 4 Change the gas bottle.
Secure the new gas bottle.

Remember to remove the LPG level sensor from the empty gas bottle (applies only to vehicles with Smart Level).

Fit the sensor to the full gas bottle. Levels can be measured in metal gas bottles only.

- 5 Screw the hose (hose break valve) securely to the new gas bottle.
- 6 Open the gas bottle's master valve.
- 7 Models with a hose break valve only:
Open the hose break valve by holding the button down for a few seconds so that the gas pressure in the hose equalises.
- 8 Check that there are no leaks.
- 9 Turn on the required gas appliances.

After changing a bottle, there may be air in the gas lines. This may make it difficult to light, for example, the hob.

Repeat attempts until gas finally reaches the appliance.

In view of the fire risk, take great care.

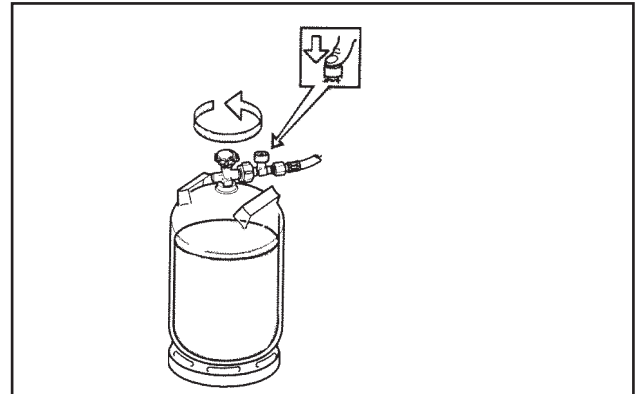

Press the button so that the hose break valve opens.
If the hose break valve is closed, the gas appliances cannot be lit.

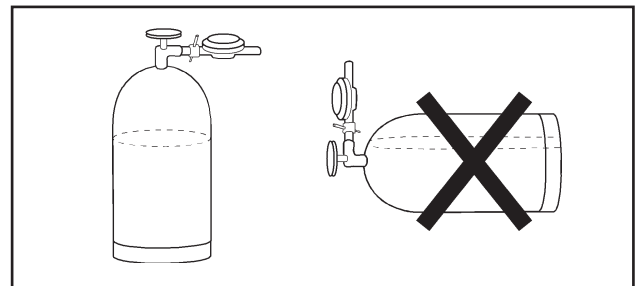

The gas bottle must be stored upright.



WARNING!

Flammable gas is dangerous!

When changing gas bottles, ensure that the area is free from naked flames and glowing or hot objects that may ignite the gas.

USING THE LEAK INDICATOR

Certain models have a leak indicator.

Check the gas system for leaks as follows:

- 1 Turn off any gas appliances (hob, boiler, refrigerator) and wait till the flame failure safety devices have cooled.
- 2 Open all the ventilation valves in the motorhome.
Open the hob's operating valves too.
- 3 Press the button on the leak indicator.
- 4 Check if there is gas bubbling through the liquid in the glass dome. There must be no bubbles in the liquid.
Watch for at least 10 seconds. Preferably, the test should be conducted for one minute.

If bubbles appear even though all the gas appliances are turned off, there is a leak in the gas system.

Close the master valve on the gas bottle immediately and visit the nearest KABE service workshop to have the leak repaired.

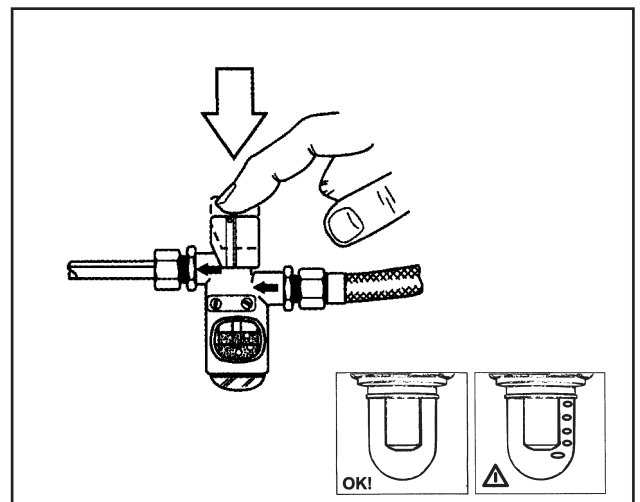

REFRIGERATOR

The refrigerator is powered by bottled gas or a 230 V electricity supply.

While travelling, the refrigerator can also be powered using the vehicle's 12 V supply.

Certain motorhomes have compressor-driven refrigerators. These refrigerators are powered solely by the 12 V supply.

Refrigerator settings are accessible on both the refrigerator and the motorhome's control panel.

There may be a certain odour when the refrigerator is first used. This disappears after a few hours. Ventilate the room well.

The refrigerator reaches operating temperature after a few hours.

See also the refrigerator manufacturer's use and care instructions.

Use

Important!

Clean the refrigerator before use.



In certain models, the refrigerator has an automatic energy selector (AES). With this, the refrigerator is primarily powered by the 230 V supply. If the motorhome is not connected to a 230 V supply, the refrigerator switches to gas operation.

Throughout travel, the refrigerator is powered by the vehicle's 12 V supply.

For other models, refrigerator operating mode has to be set.

A refrigerator with AES uses the 12 V supply throughout travel. In breaks or stops, the refrigerator automatically selects another operating mode. There is a delay of around 15 minutes before the refrigerator switches to gas operation. This is so that the vehicle can fuel at a petrol station before gas operation starts. For longer petrol station stops, refrigerator gas operation must be turned off manually.

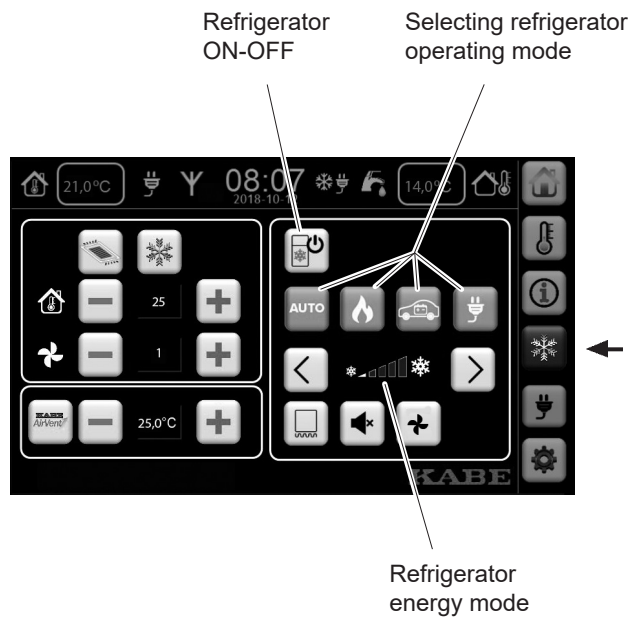

See the manufacturer's user instructions for full details of use and maintenance.

Using on a 230 V supply

- 1 Ensure that the motorhome is connected to a 230 V supply.
- 2 Via the ON-OFF button, ensure the refrigerator is on.
- 3 Select operating mode on the control panel. 230 V or automatic (AES).
- 4 If necessary, adjust the refrigerator's temperature setting.

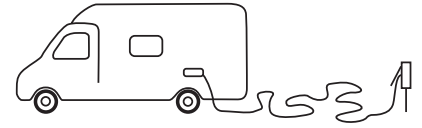

ON-OFF



Bottled gas operation

- 1 Open the valve on the gas bottle.
- 2 Open the gas supply's cut-off valve.
- 3 Via the ON-OFF button, ensure the refrigerator is on.
- 4 Select operating mode on the control panel. Gas or automatic (AES).
- 5 If necessary, adjust the refrigerator's temperature setting.

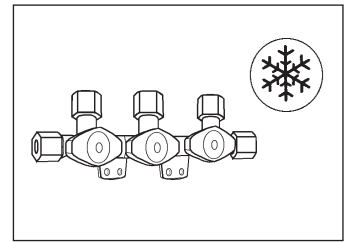

Use



ON-OFF



NB!
When the refrigerator is being operated on gas during travel, all the measures prescribed by the laws of the country through which the motorhome is travelling must be observed.
Bottled gas operation while travelling is prohibited in certain countries.
The use of bottled gas is always prohibited in and around petrol stations!

Using on a 12 V supply

A 12 V supply can only be used during travel.

- 1 Via the ON-OFF button, ensure the refrigerator is on.
- 2 Select operating mode on the control panel. 12 V or automatic (AES).
- 3 If necessary, adjust the refrigerator's temperature setting.



ON-OFF



Turning off the refrigerator

Turn off the refrigerator in accordance with its user instructions.

Ensure the refrigerator's supply valve is closed.

When the refrigerator is turned off, its door should be left open. This helps to stop mould forming in the interior.

If the refrigerator is not going to be used for some time:

- Empty the refrigerator. Defrost and clean it.
- Fit the winter hatches to the refrigerator's ventilation grille.



ON-OFF

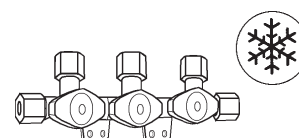

GAS HOB

KABE Travel Master has various types of hobs in its different models. This user manual gives instructions for each model. Please read the applicable instructions.

The hob's burners are equipped with a flame failure safety device. This automatically cuts off the gas supply if the flame goes out (e.g. if a liquid boils over).

Before the hob can be used, the following gas valves must be opened.

- the gas bottle's main valve.
- the hob's supply valve is in a cupboard adjacent to the hob.

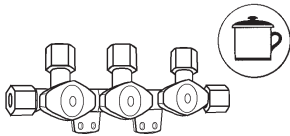

Use

USING THE GAS HOB

- 1 Raise the hob's glass lid and any flame guard.
The glass lid must be up whenever the hob is warm.
It must be possible to see the entire lighting process from above. Do not have a pan or any other object preventing this.
- 2 Turn the burner's control to the "high flame" symbol.
- 3 Press the burner's control in and light the flame by pressing the ignite button. Release the ignite button when the flame has lit.
- 4 Hold the control down for around 10 seconds (so that the flame failure safety device gets hot).
- 5 Place the cooking vessel centrally on the burner.
Do not use a cooking vessel larger than the grille (risk of the hob edge getting hot).
Do not allow the flame to lick around the sides of the vessel.
Cooking vessels with bowed or misshapen bottoms must not be used.

TURNING OFF THE GAS HOB

- 1 Turn the burner's control to the off position. Wait for the flame to go out.
- 2 Leave the hob's glass lid up until the burners have cooled.
- 3 Close the hob's supply valve (in the cupboard under the hob).



WARNING!

Risk of injury!

The hob's components are hot during and after use. Take care to avoid burns.

When cooking with a gas flame in the stove, oven or grill, extra ventilation is important. Open a window to ensure adequate ventilation.

The gas hob must not be used to heat the motorhome.

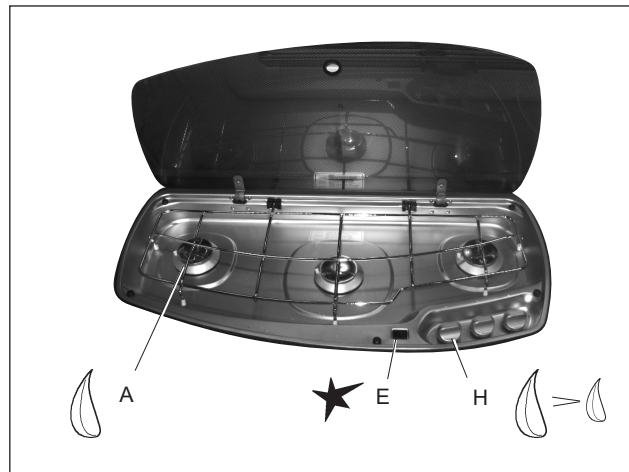

The gas hob

- A Burner
- E Ignition button
- H Burner supply control

NB!

The glass lid must not be closed while any of the burners is alight or hot.

Important!

See also the manufacturer's use and care instructions (supplied with the hob).

MICROWAVE OVEN

Certain models have a microwave oven (factory-fitted option for others).

The microwave can only be used when the motorhome is connected to a 230 V supply.

The microwave must not be used for more than 30 minutes at a time. It must then be allowed to cool (to avoid overheating).

Clean the microwave with a damp cloth.

See also the manufacturer's instructions.



Max. 30 minutes

HEATING SYSTEM



The motorhome's control panel

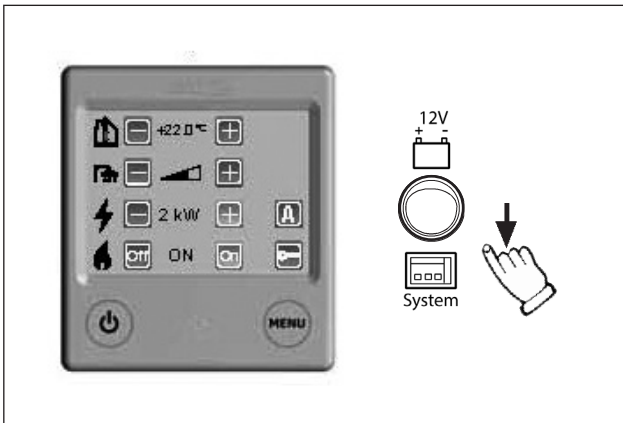

The boiler's control panel

The boiler's control panel is connected to the motorhome's electrical system. Thus, the boiler's most used functions are accessible from the motorhome's control panel (along with other heating system functions).

In normal use, the boiler is controlled from the motorhome's control panel.

The boiler's control panel is unobtrusively sited (e.g. in a wardrobe).

There is a switch next to the boiler's control panel. It is used to set whether the boiler's control panel is:

- connected to the motorhome's electrical system and, consequently, to the motorhome's control panel; or,
- connected directly to the battery.

In normal use, the switch should be in the "System" position.

If the motorhome's electrical system is threatened by interruptions, the boiler can be kept running by putting the switch into the "12 V Battery" position.

For full information of the boiler's various functions, see the separate user instructions from ALDE.

STARTING THE HEATING SYSTEM

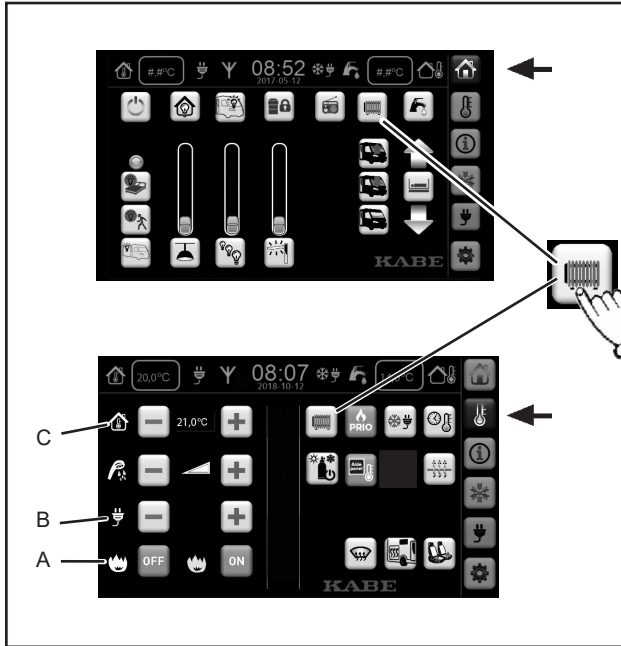

To start the switched-off heating system, press the “Heating ON-OFF” icon.

The “Heating ON-OFF” icon is accessible from the control panel’s “Start” and “Heating” menus.

Ensure that the following settings are as per instructions:

A Heating using bottled gas.

B Heating using a 230 V supply.

C Setting the desired temperature.

Instructions are given in separate sections.

SETTING THE DESIRED TEMPERATURE

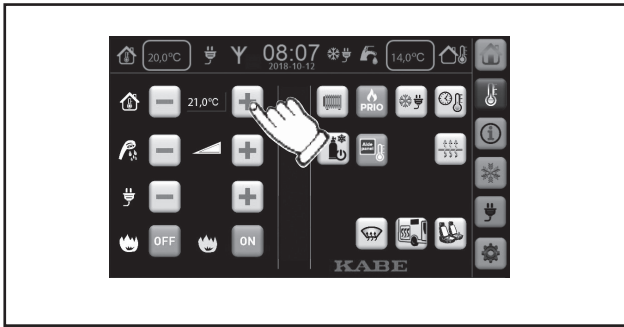

In intervals of 0.5°C, the temperature can be set from +5°C to +30°C.

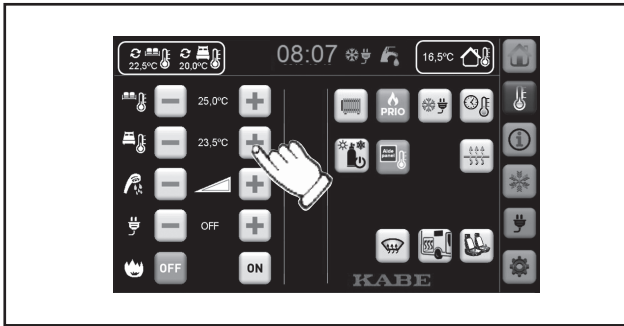

Certain models have zone heating. (KABE Imperial)

With zone heating, the temperatures of zones 1 and 2 can be set individually.



Zone 1 is the front part of the motorhome (lounge seating).



Zone 2 is the rear part of the motorhome (bed).

Use

HOT WATER



For hot water, the heating system must be on (bottled gas or electrical power supply).

In the summer, hot water but no heating of the living area is desirable. Turn the temperature setting below the current ambient temperature. The circulation pump will then not start and there will be no heating of the living area.



The boiler's hot water temperature can be temporarily raised. A greater volume of water at the desired temperature can then be used.

After around 30 minutes, the setting automatically returns to normal water heating. (The setting can also be restored manually.)

While extra hot water is being produced, the circulation pump is switched off (no heating of the living area).



WARNING!

Risk of burns.

The water's extra high temperature can cause burns. Take great care when extra hot water is being produced.

Inform all those concerned that the hot water is temporarily hotter than usual.

HEATING USING A 230 V SUPPLY.

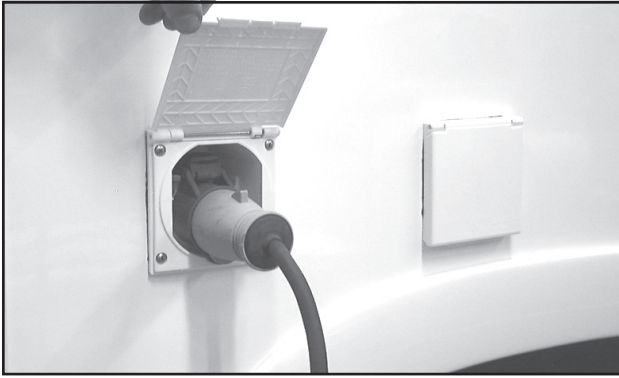

WARNING!

Risk of injuries.

Use a power cable that is approved for outdoor use.
Site the cable away from all risk of damage.
Damaged cables must be replaced.

- 1 Connect the motorhome to a 230 V mains.
- 2 Set the energy mode to electrical operation:
OFF = Switched off
1 kW = 1,050 W (requires 5A fuse in the feed).
2 kW = 2,100 W (requires 10A fuse in the feed).
3 kW = 3,150 W (requires 16A fuse in the feed).
- 3 Check that the thermostat is set at the desired room temperature.

Important!

If both electrical and bottled gas operation are selected on the control panel, electrical operation is prioritised.

Gas operation will start up when the thermostat senses that the temperature is below the set value.

HEATING USING BOTTLED GAS

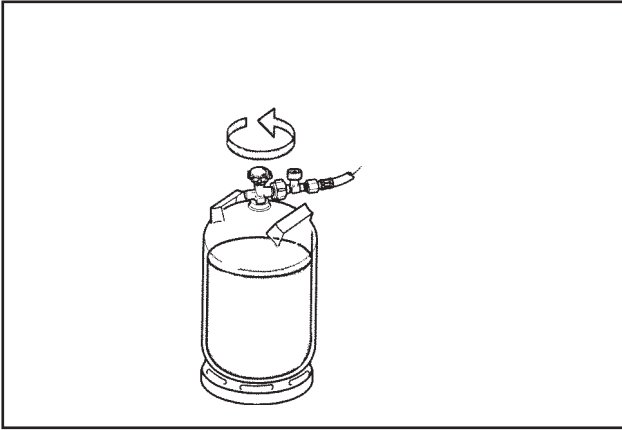

Important!

If both electrical and bottled gas operation are selected on the control panel, electrical operation is prioritised.
Gas operation will start up when the thermostat senses that the temperature is below the set value.

- 1 Open the master valve on the gas bottle.
- 2 Open the supply valve to the boiler.

Use

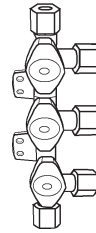
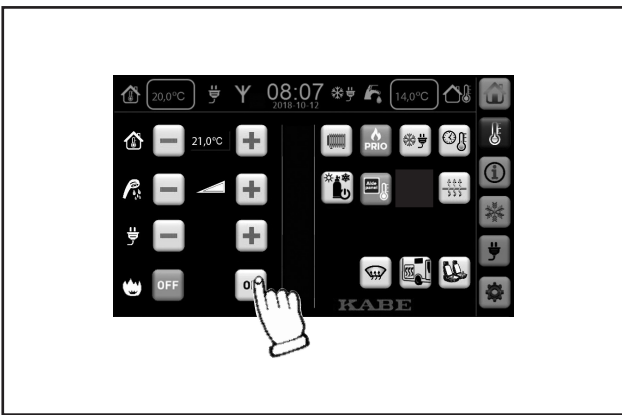

- 3 Press bottled gas operation ON.

SETTING FLOOR HEATING

All KABE Travel Masters have floor heating (system differs between models). Below, read what is relevant to your motorhome.

See also section 4, "Descriptions".

AGS II floor heating system

Many KABE motorhome models have floor heating integrated with the motorhome's overall heating system. This means that the floor heating's temperature automatically follows that of the overall heating system. The temperature of floor heating is regulated by the room temperature.

This is a well-proven technology that gives a comfortable floor temperature without having to set floor heating separately.

AGS II Pro floor heating system

Certain KABE motorhomes have an AGS II Pro floor heating system (also available as a factory-fitted option). Floor heating here has its own circuit with separate circulation.

Start the floor heating's circulation pump on the control panel.

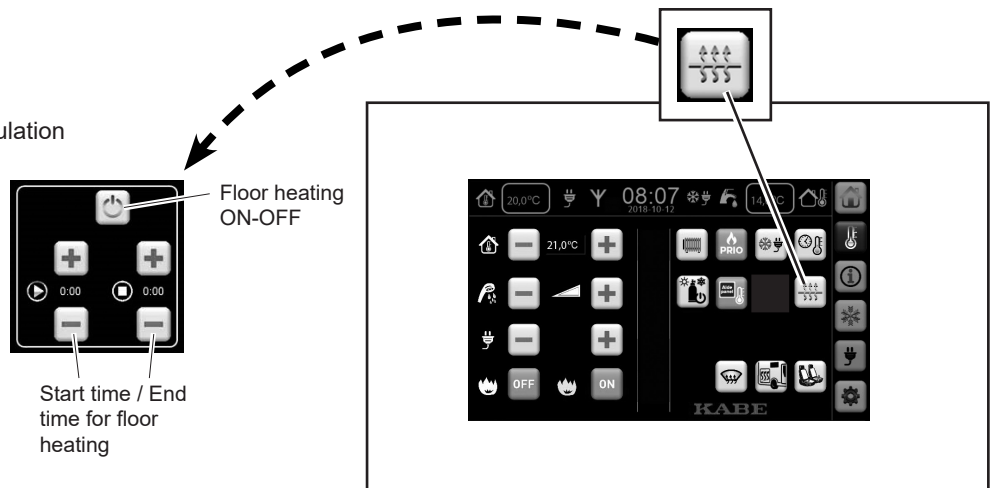

Floor heating maintains an even floor temperature whatever the motorhome's room temperature.

Adjust the floor heating temperature by turning the "shunt" control.

The factory-set value for the floor heating's shunt valve is 6.

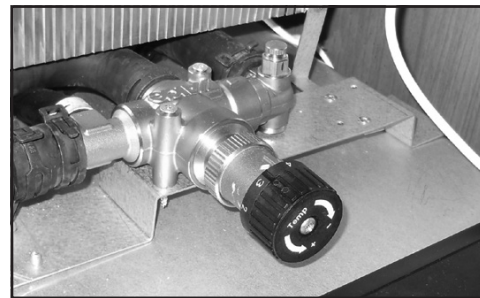

AGS II Pro floor heating is recognisable from the shunt valve by the boiler.

HEATING THE LIVING AREA DURING TRAVEL

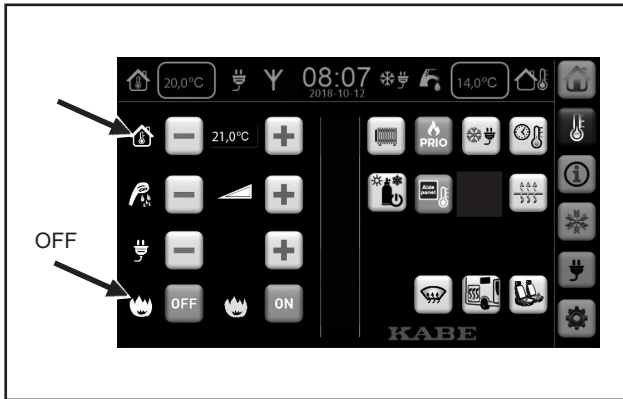

Certain models have a heat exchanger that transfers heat between the heating systems of the vehicle part and the living area part.

During travel, a motorhome with a heat exchanger can heat the living area's heating system using the vehicle's engine as follows:

- 1 Start the living area's circulation pump by starting the heating system from the boiler's control panel.
- 2 Check that the thermostat is set at the desired room temperature.
- 3 If heating is to be solely via the heat exchanger and the vehicle engine, heating from the boiler must be switched off (bottled gas operation off).

WINTER CONNECTION (MOUNTAIN CONNECTION)

In winter connection, the boiler starts when a 230 V supply is connected to the motorhome.

For the motorhome to be warm when a 230 V supply is connected, the heating system must be set as explained below.

Winter connection settings:

- 1 Activate the heating system. (D)
- 2 Turn off bottled gas operation. (A)
- 3 Select the electrical operation energy mode: 1 kW, 2 kW or 3 kW. (B)
- 4 Set the desired temperature. (C)
- 5 If the refrigerator is to start along with the heating, ensure that it is set for 230 V operation (and is switched on).
- 6 Activate winter connection. (E)
- 7 Switch off the motorhome's control panel.
- 8 Put the safety cut-out switch into the "Off" position. This prevents the battery going flat.
- 9 Disconnect the 230 V supply (pull out the 230 V supply cable).

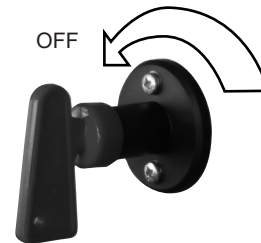
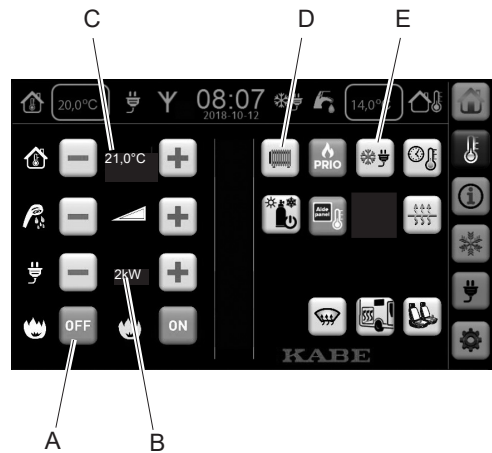

When a 230 V power cable is connected to the motorhome (or a timer turns on the power) the boiler starts in accordance with the settings.

WATER/WASTE WATER SYSTEMS

FILLING WITH FRESH WATER

Reading the fresh water tank level (A).

Flush the water system and water heater:

- if water consumption has been low (water not fresh).
- if the system has been empty for some time (long-term storage).

See also the “Draining the water system” section.

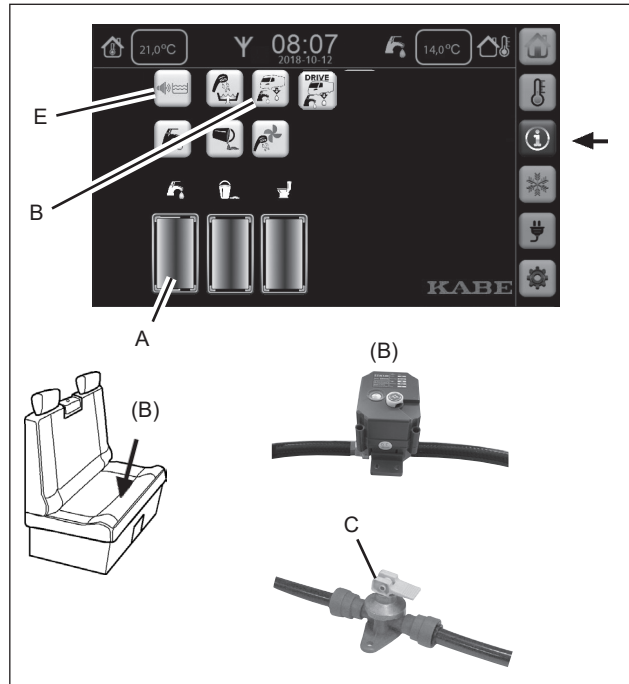

Ensure that the following outlets are closed:

- the fresh water tank’s drain valve and electric drain valves. See the control panel (B).
- the water heater’s drain valve (C) next to the boiler.

1 Activate the alarm on the control panel (E).
The alarm goes off when the tank is full.
Switch off the alarm by pressing the icon (E) again.

2 Undo the filler cap.
Fill the tank with fresh water.

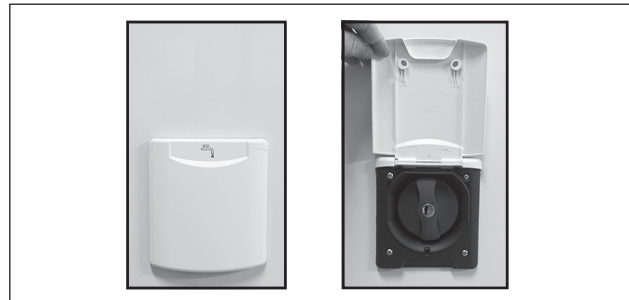

3 Start the water pump.

- Ensure that the water pump is activated on the control panel. The water pump icon must be visible. If necessary, use the button (V) to activate the water pump.
- Turn a water tap on.



4 If the water system was empty:
Fill the water heater by turning on a hot water tap until there is an even flow from the tap’s spout.
Bleed the water system by getting the water pump to pump water out in the kitchen, hand basin and shower.

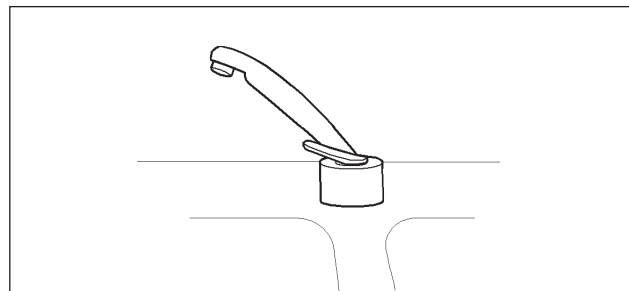

Important!

Drain the grey water tank when you fill up with fresh water. This avoids the risk of overfilling the grey water tank.

DRAINING THE FRESH WATER SYSTEM

Drain the fresh water system:

- if the motorhome is not going to be used for some time.
 - if the motorhome is being left unheated (risk of freezing).
 - if the water in the system is not fresh.
 - to renew the air cushion in the water heater.
- 1 Drain the fresh water tank and the cold/hot water hoses (B).
The water runs out beneath the motorhome.
 - 2 Open the water heater's drain valve, (C).
The drain valve (C) is located next to the boiler.
Water from the water heater runs out beneath the motorhome.
 - 3 (Certain models only.)
Open the drain cocks (D) for the cold and hot water hoses. Water runs out beneath the motorhome.
 - 4 Turn on all the water taps so that the water pump starts and flushes all water from hoses and the pump itself.
Ensure that taps are on for both hot and cold water (taps in an open position between cold and hot).
Let the water pump run until no more water is coming from the taps.
Lay the shower hose on the floor so that the "trapped" water can run out.
Applies also to the shower hose in the luggage compartment. (Certain models only.)
Press the toilet's flush button so that water can run out of the toilet's hoses and valves.
 - 5 Use the button (V) on the control panel to switch off the water pump. The pump icon goes out.
Turn on all water taps so that air can be sucked into the hoses under the influence of temperature changes.
Ensure that taps are left on for both hot and cold water (open position between cold and hot).

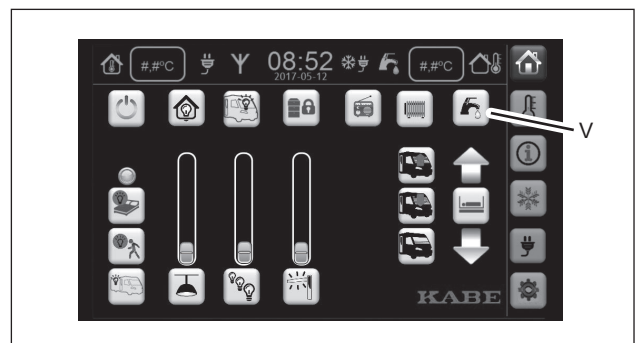
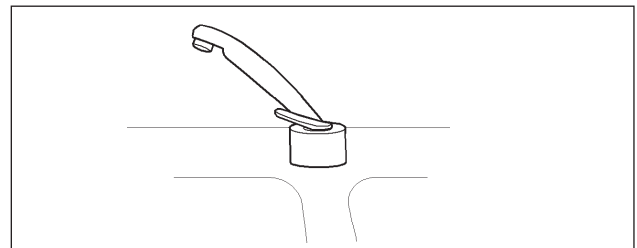
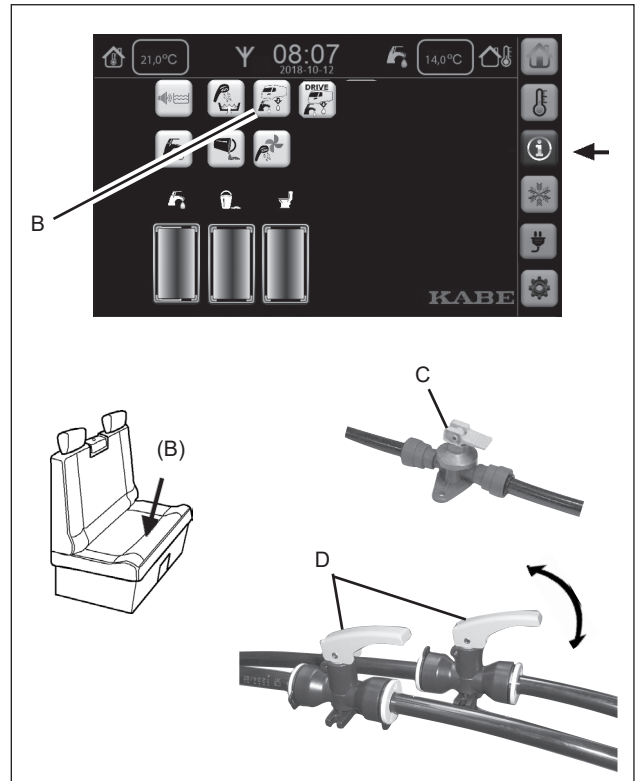

CLEANING THE FRESH WATER TANK

- 1 To clean the tank's interior, unscrew the caps (E) at the top of the tank.
- 2 Use a dish brush to clean the chambers.
If necessary, use a cleaning agent for the fresh water tank.
- 3 Rinse out the water tank and flush the water lines.
- 4 Refit the caps. Ensure that the cap gaskets seal correctly.

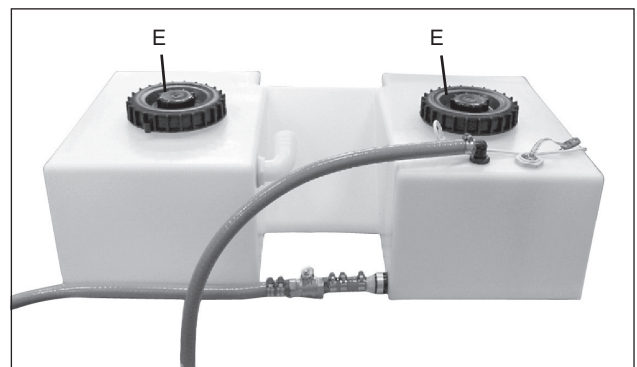

Use

DRAINING THE GREY WATER TANK

Read the grey water tank level (A).

Grey water must be emptied into a standard toilet or other approved emptying facility.

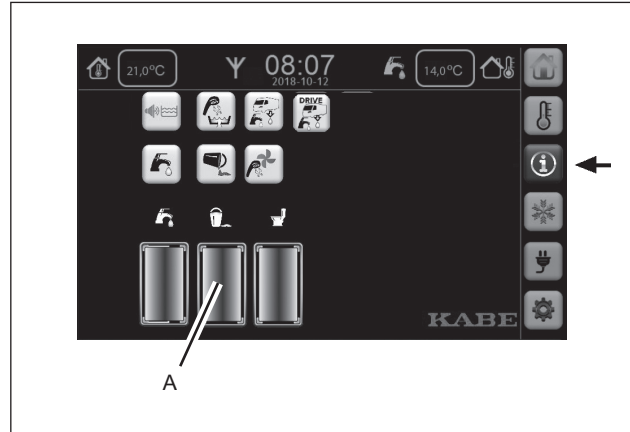

- 1 Place a suitable receptacle under the grey water tank's drainage hose (B).

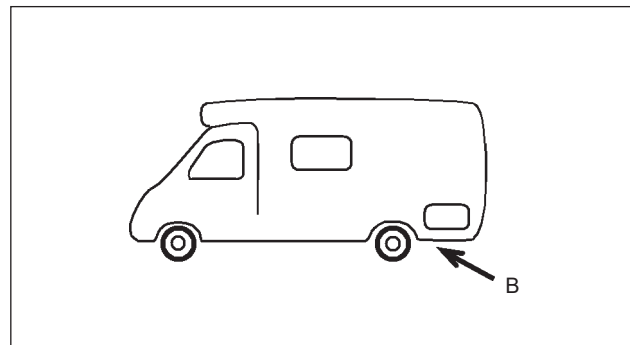

Important!

Facilitate draining by fitting a hose to the grey water tank's conical outlet.

- 2 Drain the grey water tank by starting the grey water tank pump via the switch (C).

The grey water pump can also be started from the control panel (D).



Important!

The grey water pump can only be started when the vehicle's engine has been turned off.

CLEANING THE GREY WATER TANK

Clean the grey water tank as follows:

- 1 Drain the grey water tank.
- 2 Place a suitable receptacle under the flushing outlet.
- 3 Open the grey water tank's flushing outlet.

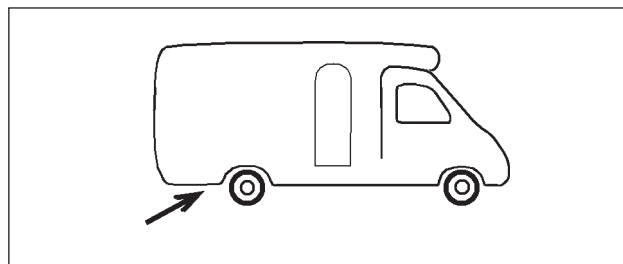

Remove the plug inside the grey water tank by raising the handle and pulling up the plug. Certain models may have a ball valve instead of a plug.

- 4 Flush the inside of the tank clean. If necessary, flush the grey water tank with a cleaning agent for grey water tanks.
- 5 Collect the sludge in a container and dispose of the contents at an approved site.
- 6 Close the grey water tank's flushing outlet. Refit the plug in the flushing outlet. Swing the handle downward so that the plug seals the outlet.

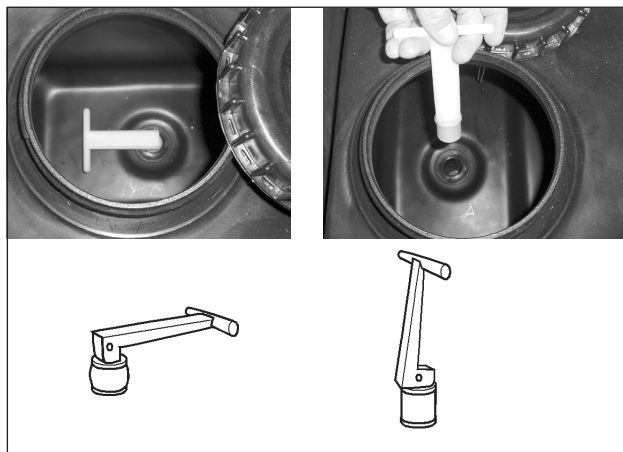

Flushing the tank clean

Certain models have a separate hose for flushing the tank with water when cleaning.

The colour-marked hose is connected to the fresh water tank.

The hose with no marking is connected to the grey water tank.

Each hose's valve is open when it is twisted in the hose's direction.

Ensure that the valve is closed before the tank is refilled for normal use.

KABE TMI:

The hoses are accessible via one of the motorhome's load doors.

KABE Van:

The hoses for flushing the tanks are under the worktop.

The hoses are accessible via the motorhome's sliding door. Remove the bottom drawer.

(To remove the drawer, see section 5, "Maintenance".)

This also makes the grey water tank's first cap accessible. The grey water tank's second cap is in the space under the refrigerator.

The grey water tank's third cap is in the space under the bed, behind the wardrobe.



KABE TMI



KABE Van

USING WATER TAPS

- 1 Ensure that the water pump is activated on the control panel (V). The water pump icon must be visible.
- 2 Use the mixer function to regulate water flow and temperature.
The blue marking indicates cold water.
The red marking indicates hot water.
In a middle position, the mixer function mixes hot and cold water.

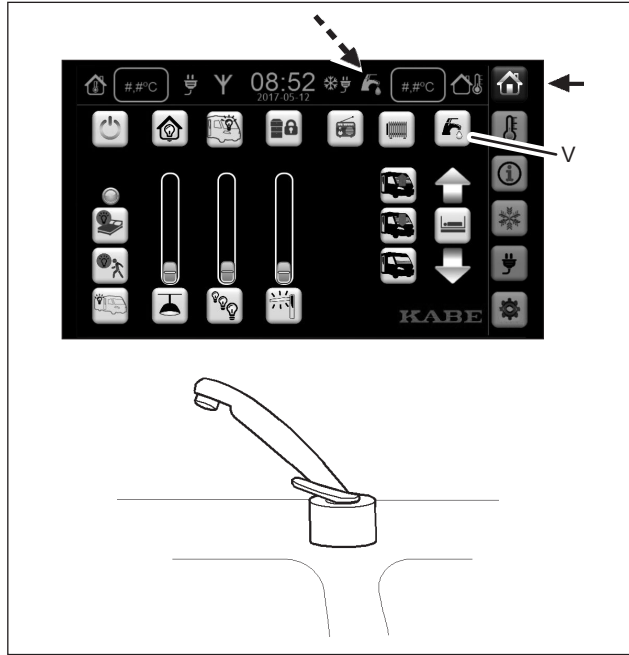

Use

USING THE WASTE WATER SYSTEM

- 1 Before using the waste water system, ensure that the grey water tank's flushing outlet is closed. Swing the handle downward so that the plug seals the outlet. Certain models may have a ball valve instead of a plug.
- 2 Do not pour boiling liquids into the waste water system.

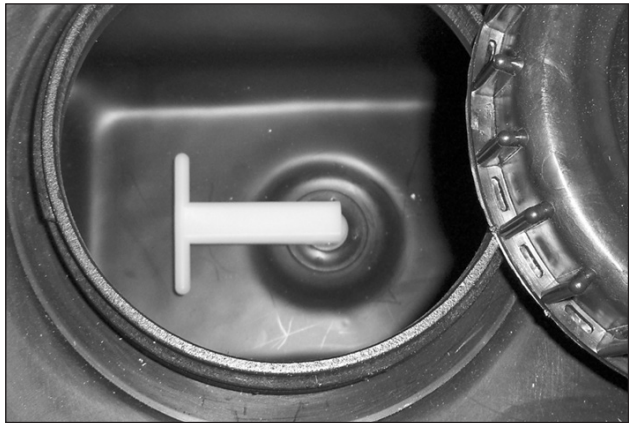

USING THE SHOWER

- 1 Ensure that the water pump is activated on the control panel. The water pump icon must be visible.
If necessary, a greater volume of hot water can be set some minutes before using the shower.

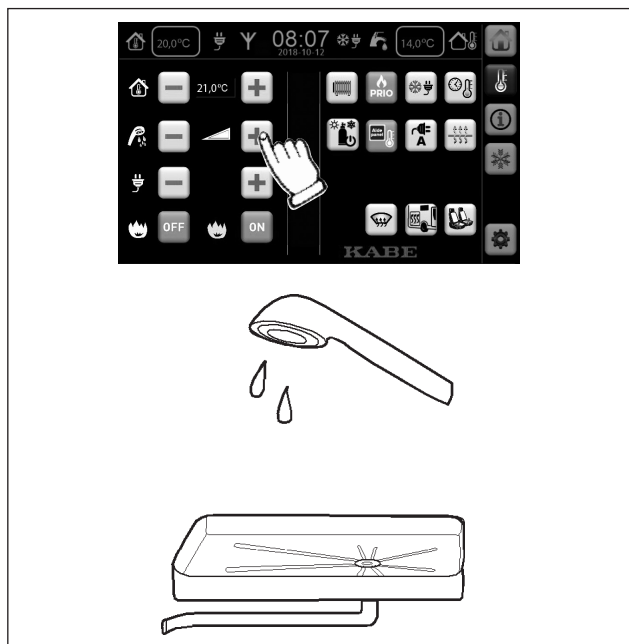

CINDERELLA MOTION TOILET

The Cinderella Motion incinerating toilet (certain models only or factory-fitted option).

This toilet is intended solely for human waste and toilet paper.

PREPARING THE TOILET FOR USE

Ensure that bottled gas is available and that the supply valves to the toilet are open.

Incineration also requires functioning electrics. The motorhome's 12 V supply must be available throughout incineration.

The toilet's incineration function requires fully functioning ventilation. Ensure that both air intake and exhaust ventilation are clear. For example, snow must not impede toilet ventilation. If necessary, a chimney extension can be fitted. A chimney extension must not be in place during travel.

USING THE TOILET

Use the toilet's purpose-designed paper bags. Use a new paper bag at each visit.

After visiting the toilet, "flush" by pressing the start button.

Before incineration can start, the paper bag must fall into the ash bowl. If the bag is light, there is a risk that it will not fall correctly. If necessary, bag weight can be increased by pouring in a little water.

Incinerating the toilet's waste takes around 1 – 2 hours. For incineration to work, the toilet lid must be down.

Even if incineration is not finished, the toilet can be used again. Incineration is interrupted when the lid is raised. There is no incineration when the toilet is in use.

Incineration resumes when the start button is pressed.

Status indication is given on the toilet's panel.

- Green is normal.
- Yellow is incineration in progress.
- Red is a function fault.

EMPTYING THE TOILET

The toilet must be maintained as per the manufacturer's instructions. Recommended intervals:

- Empty the ash bowl at least once a week.
- Clean the ash bowl at each third emptying.
- Clean the catalyst as per instructions.

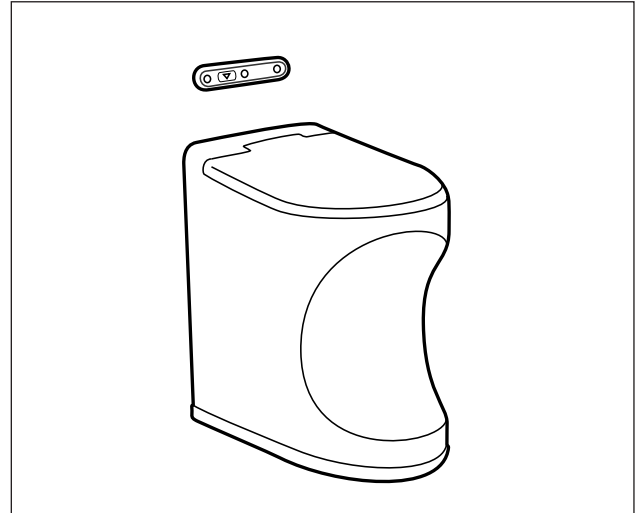

WARNING!

This toilet is intended solely for human waste and toilet paper.

Incineration of other materials can present risks.

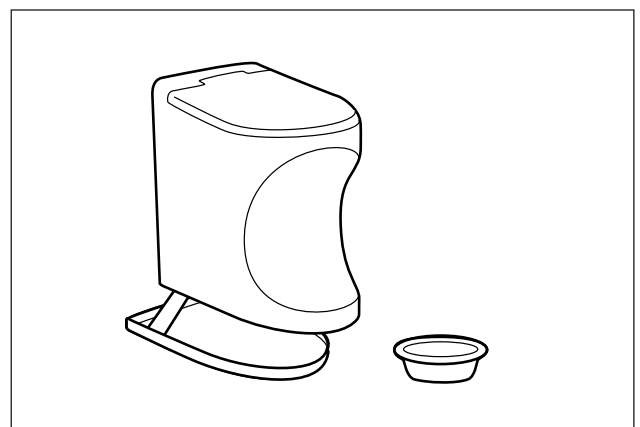

See the manufacturer's user instructions for full details of use and maintenance.

THETFORD C263 TOILET

PREPARING THE TOILET FOR USE

Before using the toilet:

Add sanitary fluid and water to the waste tank so that its bottom is covered by water (around 2 litres).

Add the sanitary fluid via the emptying spout (not via the toilet bowl).

Sanitary fluid can be bought from KABE distributors.



Use

USING THE TOILET

Ordinary toilet paper can cause blockages. Use Aqua Soft toilet paper instead. This toilet paper is extra soft, disintegrates rapidly, prevents blockages and makes it easier to empty the waste tank.

Press the flush button once to activate the control panel. Next, flush the toilet by holding the flush button down for several seconds.

The toilet can be used with the valve blade open or shut. (B)

- 1 Flush a little water into the toilet bowl by pressing the flush button (A).
- 2 Use the lever (B) to open the valve blade.
- 3 After use:
Flush the toilet bowl clean by pressing the flush button (A).
- 4 Close the toilet's valve blade.

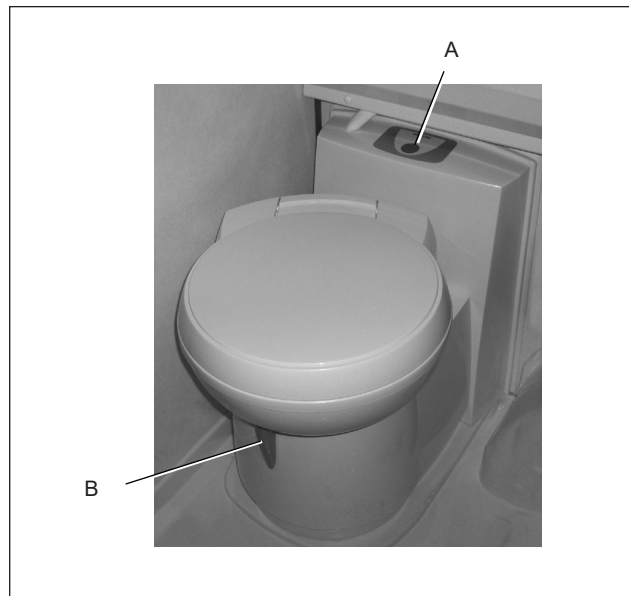

Important!

So that the water pump can start, the water pump must be activated on the control panel. The water pump icon must be visible.

Important!

See also the manufacturer's use and care instructions.

EMPTYING THE TOILET

- 1 Close the toilet's valve blade (B).

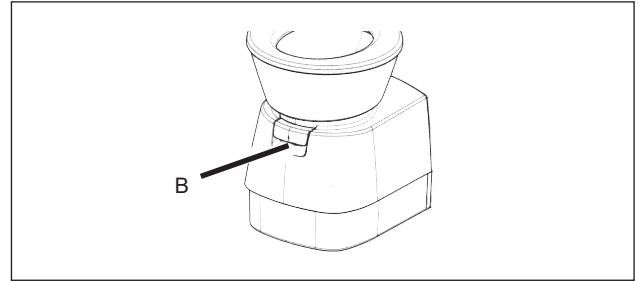

- 2 Pull out the waste tank.

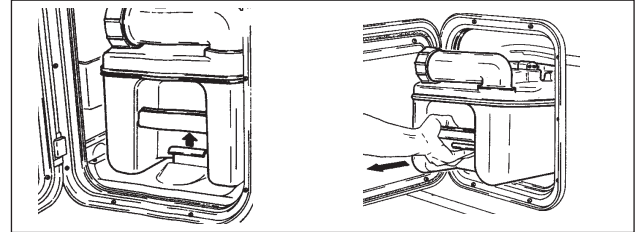

- 3 Carry the waste tank or pull it along on its wheels.

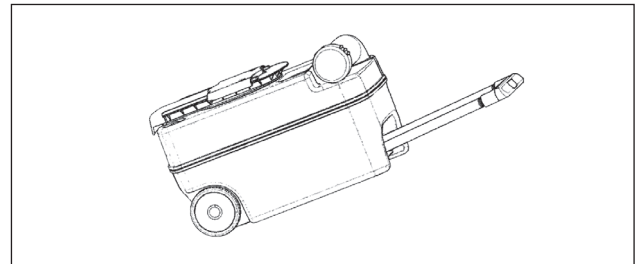

- 4 Empty the waste tank into a standard toilet or other approved emptying facility. Hold the air valve down while the contents are running out of the waste tank.

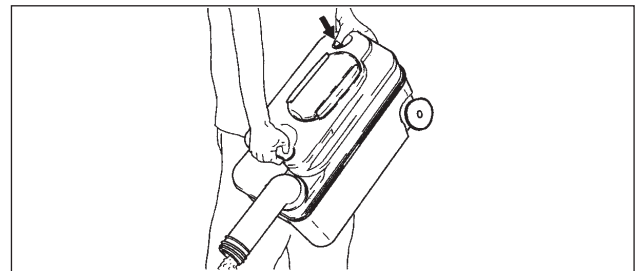

Important!

Do not press the air valve before the emptying spout is pointing downward.

- 5 Add sanitary fluid and water to the waste tank so that its bottom is covered by water (around 2 litres). Add the sanitary fluid via the emptying spout (not via the toilet bowl). Sanitary fluid can be bought from KABE distributors.

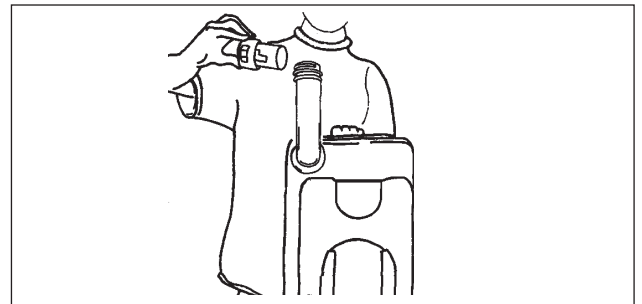

- 6 Put the cap back on the emptying spout.
7 Push the waste tank back under the motorhome's toilet.

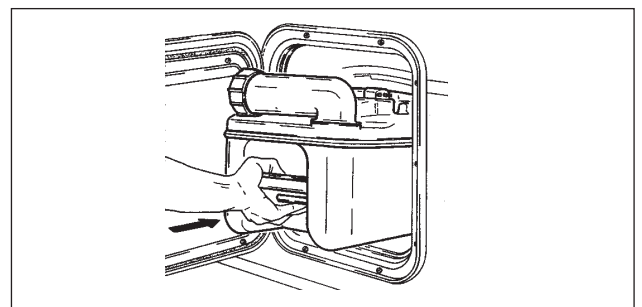

BATTERY CHARGING

CHECKING BATTERY CHARGE

Read the battery's voltage level on the control panel.

To read the starter battery's charge level, the vehicle's ignition must be on (but without the engine running).

Before reading:

- Ensure that the battery is not being charged (i.e. engine not running and 230 V supply not connected).
- Switch off as many lights as possible.

The following are guideline values at 20°C:

- > 12.5 V Battery fully charged.
- 12.2 V – 12.5 V Battery 50% charged.
- < 12.2 V The battery needs charging.

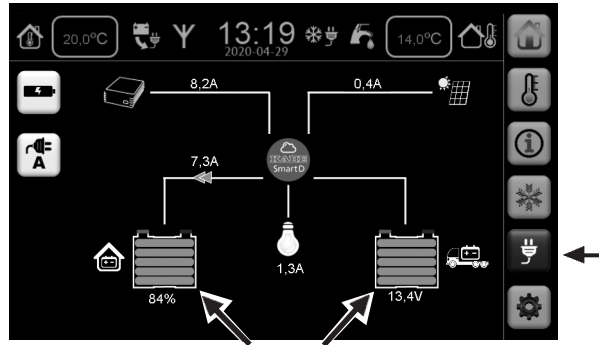

Use

CHARGING BATTERIES

While the motorhome is connected to a 230 V supply, the living area's battery is automatically charged by the battery charger. An icon is displayed on the control panel.

The battery charger also trickle charges the vehicle's starter battery.

The battery does best when charged continuously for at least 24 hours. To "top up", the battery can be charged for short periods. However, to maintain the battery's full capacity, it should be given a full charge from time to time.

See also "Descriptions – Electrical system".

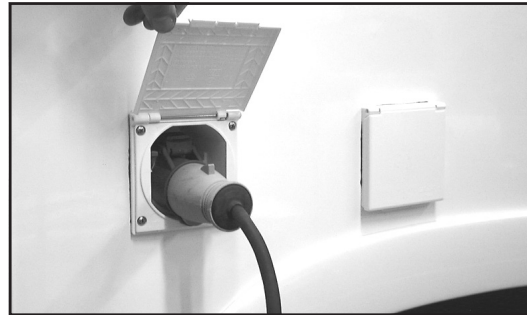

SILENT MODE

The battery charger can be set to operate silently (silent mode).

The battery is then charged at a lower power.

Set the times when silent (reduced) mode is to start and stop.

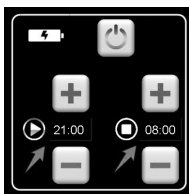

Silent mode ON-OFF

Start time / End time for Silent mode

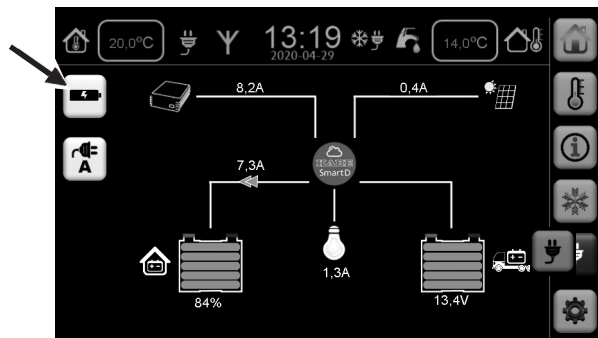

AWNING

Certain vehicles have an awning.

The awning is intended to provide shade from the sun.

When the awning has been rolled out, its support legs must be lowered so that they support the awning's outer edge. Anchor the awning's outer edge to the ground.

Throughout rolling the awning out or in, support its outer edge.

Before rolling the awning in, remove any leaves and debris.

In windy weather, the awning must be rolled in. Wind risks lifting the awning, even if it is correctly anchored. Lifting risks damaging the awning, the vehicle and the surroundings.

A damp awning should be dried before it is rolled in.

Sometimes, the awning must be rolled in even though it is damp. In these cases, roll it out again as soon as possible so that it can dry.

There is a risk of damage if a damp awning is kept rolled in.

The awning can also be damaged by heavy loads (e.g. snow).

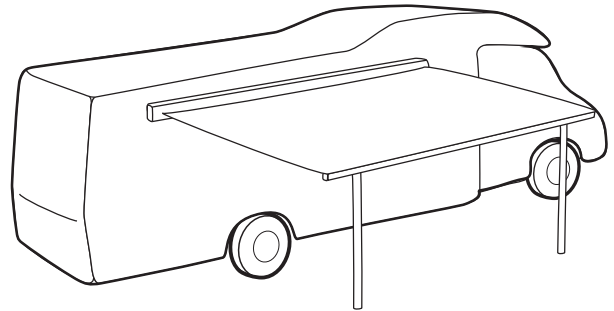

WARNING!

Risk of injury.

Wind can lift the awning. Ensure that the awning is rolled in when the weather is windy.

Never leave a rolled out awning unattended.

See the manufacturer's user instructions for full details of use and maintenance.

DESCRIPTIONS

DESCRIPTIONS – VEHICLE

Each KABE Travel Master is built on a “base” supplied by vehicle manufacturer Mercedes-Benz.

For the vehicle part of the motorhome, the vehicle manufacturer provides a separate user manual. This gives instructions and descriptions relating to the vehicle’s functions, operation and maintenance.

Study the vehicle’s user manual. The vehicle must be maintained as per the user manual or servicing instructions.

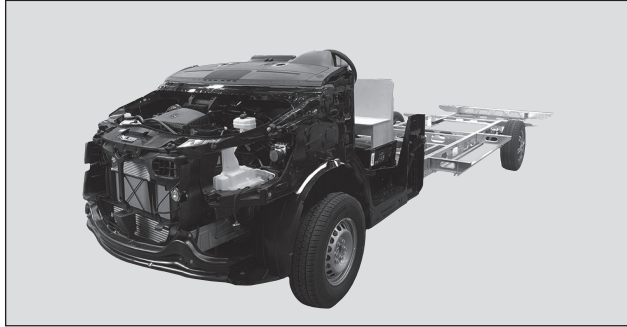

TMI vehicle part (fully integrated motorhomes).

CHASSIS

Each KABE Travel Master is built on a low-profile, light chassis. The rear axle and chassis are provided by AL-KO.

KABE Van is built on a Mercedes Sprinter.



Vehicle part (semi-integrated motorhomes).

TOW HOOK

KABE offers fully integrated motorhomes with a factory-fitted tow hook (option) that can be removed/refitted with or without tools. The tow hook must not be fitted when driving without a trailer.



KABE Van vehicle part.

RUNNING LIGHTS

Many of the running lights used by our motorhomes are of the LED type. These consume little energy and have long service lives. The vehicle’s electrical system cannot sense if these LED lights go out.

Parking

When you have parked: Open and close the driver’s door.

The vehicle part of the motorhome is programmed to have a few functions still operating during short stops. By opening and closing the door, you confirm that the vehicle is parked.

Side lights go out and a few other functions shut down.

WHEELS

The pressure and wear of tyres must be checked regularly.

After changing a wheel:

Retighten the wheel bolts after around 50 km (applies also to new vehicles).

Aluminium rims

The tightening torque for wheel bolts in aluminium rims is 180 Nm.

Steel rims:

The tightening torque for wheel bolts in steel rims is 180 Nm.



Using the right wheel bolts for your chosen rim is vital. Wheel bolt contact area on the rim can vary with different rims. Using the wrong wheel bolts to fit a rim can cause damage.



WARNING!

Check that wheel bolts are correctly torqued during the first trip and after wheel fitting.

Use the right type of wheel bolt.

Tyre pressure

To counteract tyre deformation in long-term storage, pressure should be increased to 550 kPa (5.5 bars).

Recommended on-road tyre pressures: see the table.

Stated values are for cold tyres.

	A	B	C
	500 kPa (5,0 bar)	450 kPa (4,5 bar)	---
	500 kPa (5,0 bar)	430 kPa (4,3 bar)	400 kPa (4,0 bar)
KABE Van	370 kPa (3,7 bar)	490 kPa (4,9 bar)	---
KABE Van	420-480 kPa (4,2 - 4,8 bar)	390-430 kPa (3,9 - 4,3 bar)	---

SNOW CHAINS

For the fitting and use of snow chains, see the instructions from the manufacturer and Mercedes.

Comply with local regulations on the use of snow chains.

SUPPORT LEGS

HYDRAULIC SUPPORT LEGS

Certain models have hydraulic support legs. Model AL-KO HY4.

The hydraulic support legs are activated via a separate, hand-held control.

The hydraulic support legs are programmed for fixed positions.

- Autolevel (camping).
- Automatic retraction (before travel).

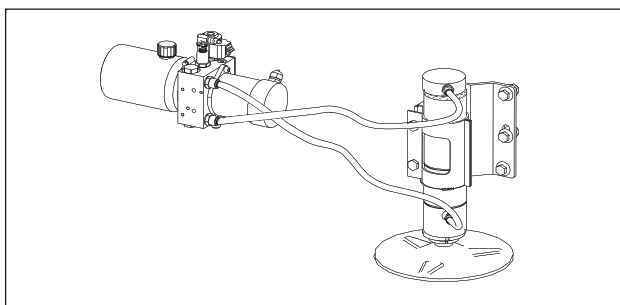

Each support leg has a hydraulic pump that is driven by the motorhome's living area battery. The support legs are only active when the vehicle's ignition is switched off.

Automatic retraction

Press the "retract support legs" button. This position is to be engaged before travel. The motorhome must remain motionless until the indicator light at the driver's station turns green. All support legs must be fully retracted throughout travel.

Autolevel

This position is used when camping. The support legs automatically adjust the motorhome to a level position.

The support legs compensate for uneven ground. To a certain extent, the support legs can compensate for sloping ground. Nonetheless, a relatively flat parking area should be chosen.

To activate the support legs:

- Apply the hand brake.
- Put the gearbox into "Park".
- Deactivate air suspension X4 by pressing the off button on the separate hand-held control. (Certain models only.)
- You can then switch off the ignition.

Certain motorhomes have air suspension X4 (does not apply to air suspension X2). Switch off air suspension before activating the hydraulic support legs. Both air suspension and hydraulic support legs sense motorhome tilt. They can thus come into conflict and counteract each other. Air suspension must only be used during travel. Support legs must only be used when camping.

Maintenance

Maintenance instructions must be followed as per the manufacturer's documentation.

Emergency operation

Emergency operation instructions must be followed as per the manufacturer's documentation.



Important!

See also the manufacturer's use and care instructions.

BOTTLED GAS SYSTEM

BOTTLED GAS

Bottled gas is a petroleum product. When bottled gas burns, it gives off carbon dioxide and steam. A good supply of air is essential to ensure complete combustion. A gas hob with two burners requires up to 7 times as much air as a person undertaking heavy physical labour.

Bottled gas is heavier than, and mixes readily with, surrounding air. However, under certain circumstances, it will collect in low-lying spaces.

Bottled gas has a characteristic odour.

Bottled gas is not toxic (no known toxicity symptoms).

There are two sorts of bottled gas (i.e. liquefied petroleum gas – LPG):

- Propane (C_3H_8)
- Butane (C_4H_{10})

Because it gasifies at temperatures down to around $-40^{\circ}C$, use propane. Butane stops gasifying at approximately $\pm 0^{\circ}C$.

In Sweden, only propane is available. In other countries, butane is also sold. Ask for propane if you will be using gas in the winter.

THE BOTTLED GAS SYSTEM

The gas bottle is stored in the bottle locker.

The gas bottle locker is an enclosed, ventilated space that is separated from the living area. The locker has ventilation holes in the floor. These allow any leaking gas to escape.

The bottled gas system uses copper pipes with screw fittings. The gas bottle is connected to the gas system via an approved rubber hose.

The system has a number of valves allowing partial or total closure of the system.

The system's master valve is on the gas bottle.

In its standard version, the motorhome has three gas appliances.

- hob,
- boiler,
- refrigerator.



Each gas appliance is described in its own section.



WARNING!

Fire risk.

Bottled gas is classified as a highly flammable gas. It must be treated with respect.

If there is any suspicion of a leak, close the gas bottle's master valve and have a professional test the gas system for leaks.



WARNING!

Fire risk.

If any gas appliance is lit, driving into a petrol station is prohibited.

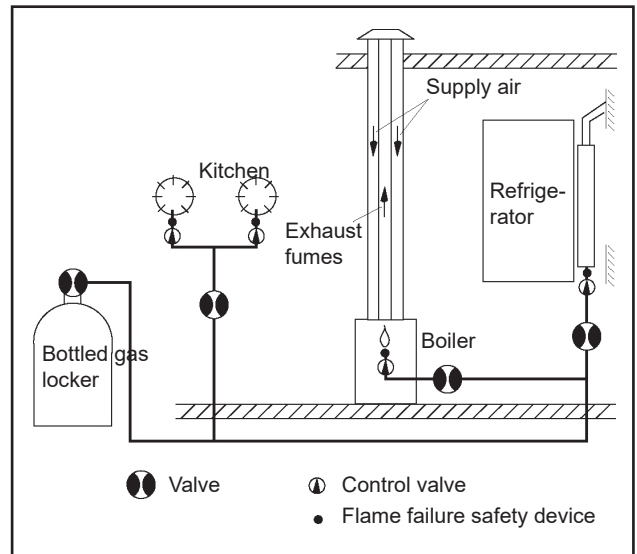

Schematic of the bottled gas system.

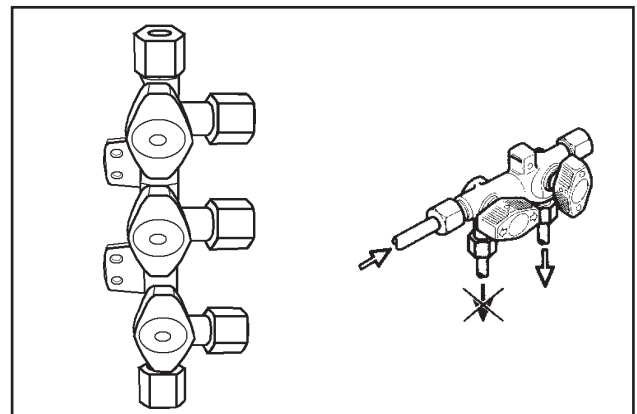

Valves are used to close off parts of the bottled gas system.

GAS BOTTLES

Each gas bottle holds 11 kg of propane (in Sweden).

Gas can be stored in a bottle with no limitation of time. The gas is compressed to a liquid form. In a newly filled gas bottle, the liquid gas takes up to 80% of the space.

In the motorhome's gas system, the gas bottle must stand upright. See illustration. If it is used on its side, liquefied gas may seep out into the system and cause the flames in the hob burners to periodically flare up.

The gas bottle is a pressure vessel and must not be subjected to abnormal heating. Avoid having direct sunlight on the gas bottle. Because the gas bottle is a pressure vessel, it must be tested every tenth year. Each gas bottle is marked with the year it was last tested. Replace any bottle if the marking is for a date more than ten years ago.

When the gas bottle's valve is opened, gas exits via the top of the bottle and reduces the pressure inside the bottle. To compensate for this, the liquefied gas in the bottle gasifies to an extent matching the outflow of gas and exactly restoring the pressure. This process continues until the bottle no longer contains gas in liquid form.

The gas bottle's connection to the gas system has a left-hand thread.

To change gas bottles, see the instructions in the "Use" section.



The gas bottle in the bottle locker.

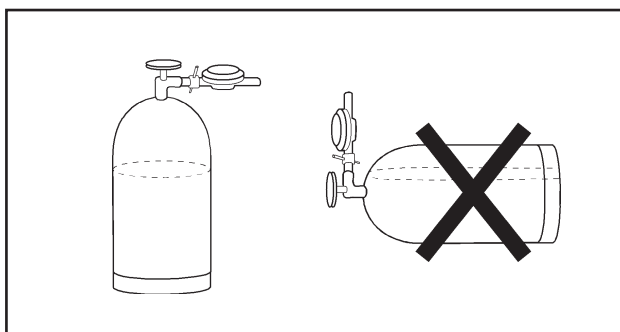

The gas bottle must be stored upright.

Certain vehicles have Smart Level.
(An icon on the control panel shows if the vehicle has Smart Level.)

Smart Level gives current readings of the liquid level in the gas bottle.

The function comprises a sensor beneath the gas bottle and, communicating with the sensor, a fixed device in the vehicle.

The gas bottle reading is shown on the control panel.

When changing gas bottles:

- Remove the sensor from the empty gas bottle.
- Fit the sensor to the full gas bottle.

The sensor can only measure liquid levels in metal gas bottles.

Smart Level can be supplemented so that liquid levels in two gas bottles can be shown on the control panel.

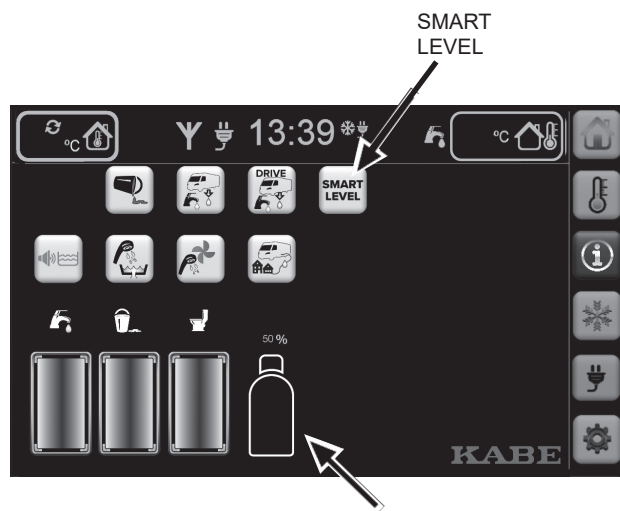

HOSE BREAK VALVE

The hose break valve is fitted on the bottled gas hose. The hose break valve is a safety device that blocks the gas flow if the hose breaks.

After changing gas bottles, the hose break valve must be opened by pressing the button. It then remains open as long as the bottled gas system is pressurised.

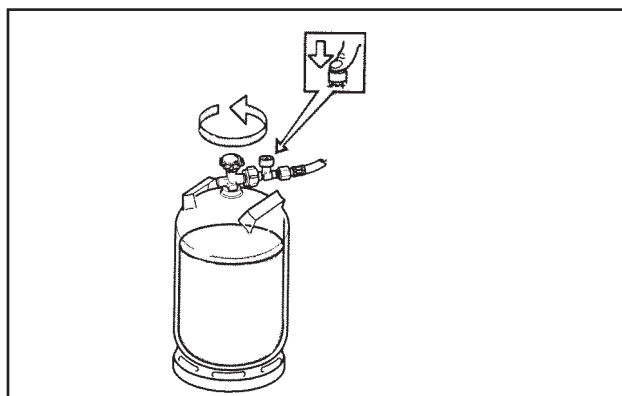

The hose break valve is fitted on the bottled gas hose.

GAS PRESSURE REGULATOR

Gas pressure regulator is also called Reducing valve.

Fitted to the wall next to the gas bottle, there is a reducing valve. This reduces the gas pressure to 3 kPa (30 mbar). All the gas appliances in the motorhome operate at this pressure.

If, for any reason, the reducing valve has to be changed, ensure that its replacement is designed for the correct pressure.

The bottled gas system also has a crash sensor that blocks gas flow in the event of a major impact. This is a safety device that prevents gas leaking out in a traffic accident. It should not trigger in normal use. If, despite this, the crash sensor does trigger, it can be reset by holding the button down with a tool for 20 – 30 seconds.



Truma MonoControl is intended for one gas bottle.



Tool for the gas pressure regulator.

A gas filter is mounted between the gas bottle and the gas pressure regulator.

The absorbent pad shall be changed at the same time as the gas bottle. It is placed at the bottom of the gas filter removable part. (Truma article number: 50681-01)

See also the manufacturer's manual.

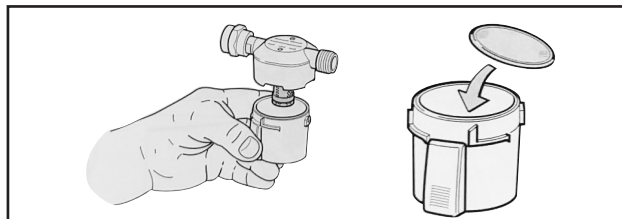

Change of the filter pad.

Truma DuoControl is intended for two gas bottles.

Turn the knob to choose primary gas bottle. Make sure the secondary gas bottle contains gas. When the primary gas bottle is empty, DuoControl automatically switch to the secondary gas bottle.

Turn the knob to switch primary and secondary gas bottle.

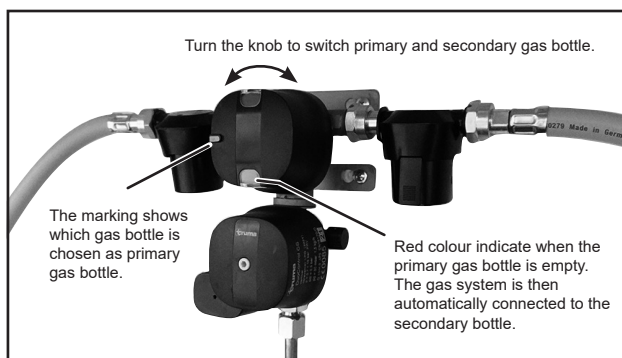

Truma DuoControl is intended for two gas bottles.

Motorhomes that have a hose break valve and a crash sensor can be set to use gas appliances while travelling. An electrical system setting adapts said system for this possibility.

When the motorhome's engine is turned off, the electrical system automatically switches off bottled gas operation of the refrigerator and boiler for 15 minutes. (This is to prevent lit gas appliances in petrol stations.) A control panel menu shows the following options:

- Wait 15 minutes before bottled gas operation starts.
- Start bottled gas operation immediately.
- Bottled gas operation to remain off.

The first option is preset until another option is selected.

Remember that any Cinderella incinerating toilet is not connected to the electrical system. It must be switched off manually before entering a petrol station. To ensure that the incinerating toilet is not lit, lift the lid.



WARNING!
Fire risk.
If any gas appliance is lit, driving into a petrol station is prohibited.



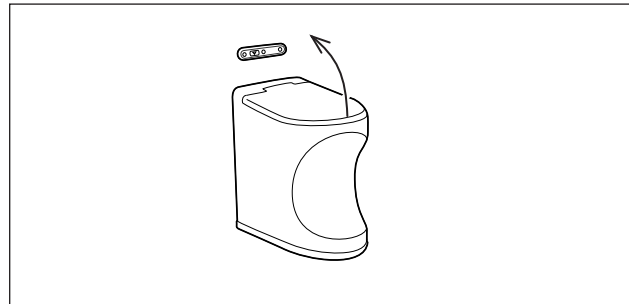

LEAK INDICATOR

Certain models have a leak indicator for bottled gas.

When the indicator's button is pushed down, gas bubbles through the fluid in the glass dome.

When all the gas appliances in the vehicle are turned off, there must be no gas flowing through the system and no bubbles in the fluid. Watch for at least 10 seconds.

If bubbles appear even though all the gas appliances are turned off, there is a leak somewhere in the bottled gas system.

If there is any suspicion of a leak, close the master valve on the gas bottle immediately and visit the nearest KABE service workshop.

The liquid level in the glass dome must be between the two marks. If necessary, fill the glass dome with leak indicator fluid (propylene glycol). Screw the glass dome in place by hand (do not use tools). The fluid can be bought from KABE distributors.

Individual joints, connectors and valves are to be checked by brushing them with a soap solution or spraying them with a leak spray. Bubbles indicate that there is a leak.

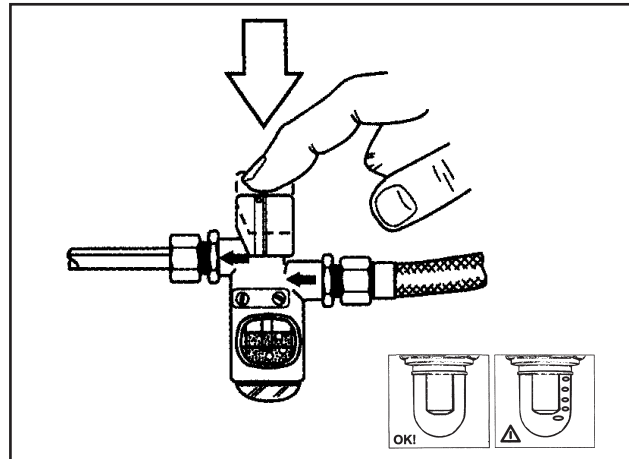

Test the bottled gas system using the leak indicator for 10 seconds. Bubbles in the fluid indicate a leak.

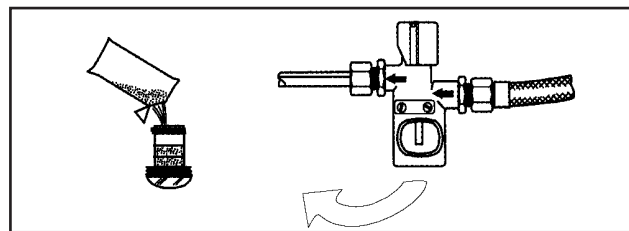

Filling the indicator with fluid.

CHECKING THE BOTTLED GAS SYSTEM

At delivery, each KABE Travel Master has been tested as per the then applicable regulations.

The following checks should also be carried out regularly:

- When in continuous use, inspect gas lines and gas appliances daily. Inspect for damage and leaks.
- Use the leak indicator to check the bottled gas system once a week and after changing gas bottles.
- At least once a year, the entire bottled gas system must be tested by a professional.

Hoses that show any signs of cracking, aging, wear or other defect must be replaced.

Bottled gas components or appliances that show signs of damage or incorrect function must be examined by a professional.

GAS PRESSURE AND TEMPERATURE

At -15°C, only half so much gas flows (per minute) from the bottle as at +13°C. This is because gas pressure falls with temperature.

If, in an 11 kg bottle, there is 2.5 kg of gas and the temperature is -15°C, the maximum flow is 350 grams per hour. At +13°C, it can provide a full 700 grams per hour.

A newly filled bottle also performs comparatively better in cold weather. At -15°C, a newly filled, 11 kg bottle can provide around 900 grams per hour. At +13°C, this becomes a full 1,800 grams per hour.

Gas bottles made of composite materials can only be used down to -10°C.

Gas quantity (kg) in the gas bottle					
	2,5	4,5	7,0	9,0	11,0
Temp.	Possible flow (g per hour)				
-18	315	427	603	767	807
-12	387	522	735	943	989
-7	458	617	871	1120	1170
-1	531	712	1010	1290	1360
+4	603	812	1140	1470	1550
+10	671	907	1280	1650	1730

BOTTLED GAS CONSUMPTION

Consumption varies with season (winter heating can use large amounts of gas) and, of course, how much you use the hob.

The refrigerator does not use many grams per hour, but is in operation several hours during the day.

Below, there are a few guidelines.

For calculation purposes, a full gas bottle holds approx. 10 kg (10,000 grams).

Hob: Low flame – high flame, 35 – 110 g per hour.

Boiler: 10 – 400 g per hour (depending on heat output).

Refrigerator: 16 g per hour (380 g per day).

REFRIGERATOR

The refrigerator is powered by bottled gas or a 230 V electricity supply. While travelling, the refrigerator can also be powered using the vehicle's 12 V supply.

Certain motorhomes have compressor-driven refrigerators. These refrigerators are powered solely by the 12 V supply.

Refrigerator settings are accessible on both the refrigerator and the motorhome's control panel.

Refrigerator model varies with motorhome.

In certain motorhomes, the refrigerator has automatic energy selection (AES). With this, the refrigerator is primarily powered by the 230 V supply. If the motorhome is not connected to a 230 V supply, the refrigerator switches to gas operation. Throughout travel, the refrigerator is powered by the vehicle's 12 V supply.

The refrigerator's electronics and control equipment are connected to the battery. Thus, if the battery is flat or disconnected, the refrigerator does not operate in any energy mode.

It takes the refrigerator several hours to reach its normal operating temperature. Start the refrigerator well in advance of your journey and, if possible, stock it with pre-cooled foodstuffs.

There may be a certain odour when the refrigerator is first used. This disappears after a few hours. Ventilate the room well.

When the refrigerator is used for the first time, and after a gas bottle change, there may be air in the gas pipes. To remove air from the gas line, use another gas appliance (e.g. the hob) for a short time.

If, as often happens with high loading of the 230 V mains at camping sites, there is a voltage drop, the refrigerator's capacity is reduced.

TURNING OFF THE REFRIGERATOR

Turn off the refrigerator in accordance with its user instructions.

Ensure the refrigerator's supply valve is closed.

When the refrigerator is turned off, its door should be left open. This helps to stop mould forming in the interior.

If the refrigerator is not going to be used for some time:

- Empty the refrigerator. Defrost and clean it.
- Fit the winter hatches to the refrigerator's ventilation grille.

TRAVEL CATCH

The refrigerator doors have travel catches. Before any journey, ensure that the doors are secured.



Important!

See also the refrigerator manufacturer's use and care instructions (supplied with the refrigerator).

The refrigerator must be cleaned before use.

NB!

Under European standard EN 732, when the refrigerator is being operated on gas during travel, all the measures prescribed by the laws of the country through which the motorhome is travelling must be observed.

Bottled gas operation while travelling is prohibited in certain countries.

The use of bottled gas is always prohibited in and around petrol stations!



ADAPTING THE REFRIGERATOR'S VENTILATION

To work satisfactorily, the refrigerator must be correctly ventilated.

The refrigerator is ventilated via grilles in the motorhome's wall.

Adapt refrigerator ventilation to the outdoor temperature as follows:

Outdoor temperature above approx. +8°C

In summer weather, it is important that the back of the refrigerator is well-ventilated. Ensure that the refrigerator's ventilation is not obstructed.

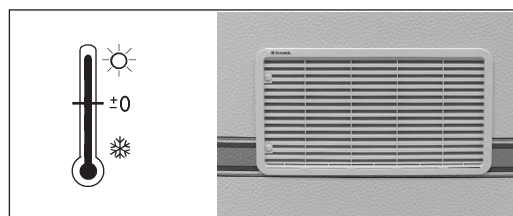

Outdoor temperature below approx. +8°C

In colder weather, the plastic hatch must be fitted to the lower ventilation grille. This restricts ventilation so that the refrigerator works satisfactorily.

To prevent dirt getting in behind the refrigerator, also use the plastic hatch when the motorhome is not being used.

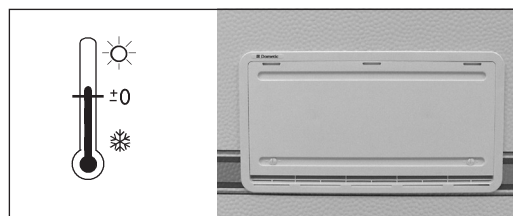

NB!

The refrigerator's ventilation grille must be kept unobstructed so that air circulation is not impeded. Obstruction can lead to overheating.

During winter operation, the grille must be partially covered using the winter hatch. However, a certain degree of ventilation is still required.

Important!

We recommend that the winter hatch is fitted if the vehicle is put away over the winter.

FAN BEHIND THE REFRIGERATOR

In warm weather, increased ventilation may be necessary for the refrigerator to get sufficiently cold.

There is a fan behind the refrigerator. A thermostat starts the fan when necessary.

On certain models, the fan can be switched off via the refrigerator's control panel.

Normally, the fan should be turned on so that it is controlled by the thermostat.

See also the manufacturer's instructions.

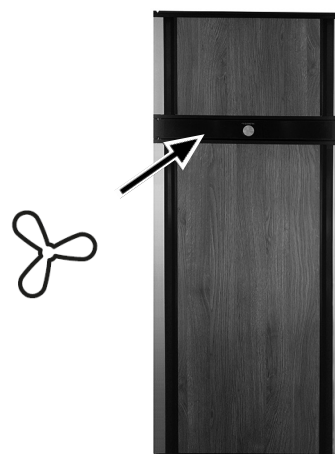

GENERAL REFRIGERATOR INSTRUCTIONS

Advice and care

The refrigerator is suitable for storing those foodstuffs that easily go off at room temperature and foodstuffs that should be served cooled. Foodstuffs should be placed in the refrigerator when they are cold or, at least, have cooled to room temperature.

Foods with a strong taste and odour easily pass these on to other foodstuffs. Thus, all foods stored in the refrigerator should be placed in sealed receptacles or wrapped in plastic film. This also prevents the foods drying out during storage and reduces frost formation in the refrigerator.

Always use a professional for the required safety inspection every other year as well as the recommended functionality checks and any repairs!

At least once a year, and before using the refrigerator after a long break, check that:

- The bottled gas system is free from leaks.
- The burner is clean and that no scrap or combustible materials have collected in its vicinity.
- The ventilation openings are not obstructed.
- The user instructions are to hand.

Storing foodstuffs

- Store foodstuffs in sealed containers, aluminium foil or similar.
- Never place warm food in the refrigerator (let it cool first).
- Products that may give off volatile, flammable gases must not be stored in the refrigerator.

The two-star freezer compartment (max. -12°C) is suitable for freezing ice cubes and the short-term storage of frozen foods.

It is not suitable for the freezing of foods.

Important!

Never place warm food in the refrigerator.

A few tips

Ensure that:

- The fridge is regularly defrosted.
- When the refrigerator is not to be used for some time, it is first cleaned and then dried. Leave the doors open.
- Liquid goods and goods with a strong odour are well packed.
- The ventilation openings are free from obstruction.
- The doors are secured by the catches throughout travel.

Making ice

It is best to make ice at night. The load on the fridge is lower then and the refrigerating element has greater reserves.

Fill the ice trays almost to the top with drinking water and place them at the bottom of the freezer compartment.

Freezing is quicker if the thermostat is temporarily set to its maximum position. However, do not forget to put it back to its normal position when the ice is ready. Otherwise, the refrigerator may get too cold.

Defrosting

Over time, frost forms on the freezing surfaces. Because it reduces freezer efficiency, this must not be allowed to build up.

Check the freezer element regularly every week. If the frost is 3 mm thick or thicker, the refrigerator must be defrosted.

When defrosting:

- Turn off the refrigerator.
- Remove all foodstuffs and ice trays from the refrigerator.
- Leave the doors slightly open.

Do not attempt to speed up defrosting with any form of heating apparatus. This can damage the refrigerator's plastic surfaces. Similarly, sharp objects must not be used to scrape ice away.

The melt water from the freezer element runs from a collection channel, through a pipe, to a bowl at the back of the refrigerator (from where it normally evaporates).

With heavy frosting and a lot of melt water, lift the drainage hose out of the bowl (accessible from the vehicle's exterior, via the ventilation grille) and let the water run from the hose down into a suitable container.

After defrosting, put the hose back into the bowl. Use a rag to dry up melt water from the freezer compartment.

When all the ice has melted, dry the refrigerator.

Foods may now be placed in the refrigerator, but do not try to make any ice until the refrigerator has become cold again.

NB!

**Layers of ice must not be removed using force.
Defrosting must not be speeded up by the use of heat sources.**

Important!

If the refrigerator is not to be used for some time, the cut-off valve in the motorhome and the valve on the gas bottle must be closed.

Cleaning the refrigerator

Clean the refrigerator regularly.

- 1 Turn off the refrigerator.
- 2 Clean the refrigerator's interior with water and a mild, unperfumed washing-up liquid. Do not use strong chemicals or abrasives. Never use cleaning agents, scouring powder, strongly perfumed products or wax polishes to clean the refrigerator's interior. These can damage the surfaces or leave strong odours.
- 3 Clean the refrigerator's exterior with a damp rag and a mild cleaning agent.
- 4 Clean the door seals with a soap solution. Wipe them dry.
- 5 Use a brush to clean the element at the back of the refrigerator. Ensure that the refrigerator is turned off when cleaning the element.

If the refrigerator is not working

Check the following before calling in a service technician:

- 1 That the refrigerator is level.
- 2 If it is possible to start the refrigerator using any of the connected energy sources.
- 3 If the refrigerator is not working on bottled gas, check that:
 - there is enough gas in the bottle.
 - the gas valves are open.
- 4 If the refrigerator is not working on 12 V, check that:
 - the vehicle's headlights are on.
 - the 12 V fuse has not blown.
- 5 If the refrigerator is not working on 230 V, check that:
 - the 230 V supply is connected to the refrigerator.
 - the 230 V fuse has not blown.

If the refrigerator is not cold enough, this may be because:

- 1 The thermostat is set incorrectly.
- 2 Too much (hot) food has been placed in the refrigerator at one time.
- 3 The door is not properly closed or the door seals are defective.
- 4 The freezer element is frosted up.
- 5 The ventilation is insufficient due to the grille being obstructed or the winter hatch throttling the air supply.
- 6 The ambient temperature is too high (e.g. because the ventilation openings are in an awning enclosed area).

If the refrigerator still does not work normally, contact a service technician.

HEATING SYSTEM

GENERAL ABOUT THE HEATING SYSTEM

KABE Travel Master has water-borne heating. Heat is distributed in the living area via:

- The heating system's convectors, which heat air along the walls. They give a comfortable indoor temperature and counteract draughts at windows.
- Floor heating, which ensures a pleasant temperature for the floor.

The figures show the heating system components in the living area and how the circulation systems are connected to each other.

For heat to circulate in the living area's heating circuit, the living area's circulation pump (MKV) has to start.

When the temperature in the motorhome is below the value set via the control panel, the circulation pump (MKV) starts. Heat circulates in the convectors.

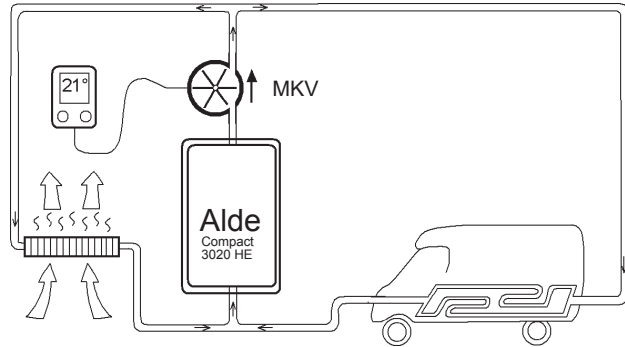

Figure 1:
Schematic of the living area's heating system.

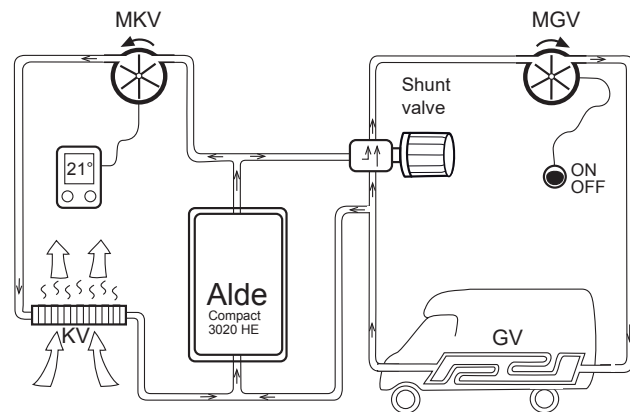

Figure 2:
Schematic of a living area with an AGS II Pro heating system (floor heating with shunt valve).

Convectors and floor heating interact in different ways depending on model or optional equipment. The two schematics show the designs.

In most Travel Masters, floor heating is connected to the convectors as per figure 1. Floor temperature follows the temperature in the convectors.

Certain KABE Travel Masters have floor heating as per figure 2.

The floor heating has its own circulation pump (MGV). This is started via a switch. Floor temperature is regulated by a shunt valve that has a separate thermostat. This gives a more even floor temperature.

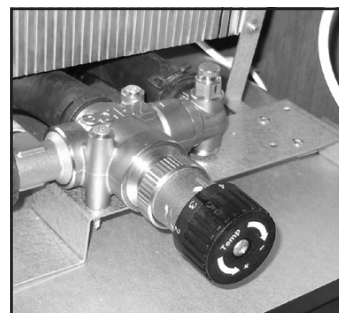

Shunt valve for floor heating (certain motorhomes only).

The heating system comprises two separate circulation systems with separate fluid systems.

- Motor circuit
- Living area's heating circuit

Certain KABE Travel Masters have a heat exchanger (V VX). The heat exchanger transfers heat from one circulation system to the other. During travel, the living area can be heated by the vehicle's engine.

When the temperature in the motorhome is below the value set via the control panel, the circulation pump (MKV) starts. Heat circulates in the convectors.

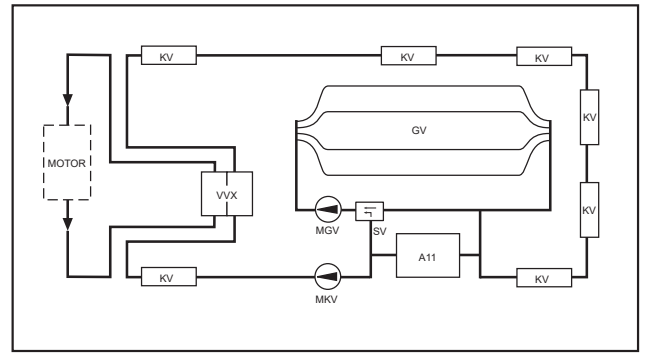

Semi-integrated motorhome with AGS II Pro (with shunt valve)

- A11 Boiler.
- GV Heating loops in the floor.
- KV Convector.
- M2 Heating unit fan under driver's seat.
- M3 Circulation pump, motor circuit.
- M4 Heating unit fan under passenger's seat.
- MKV Circulation pump, convector.
- MGV Circulation pump, heating loops in the floor.
- SV Shunt valve.
- V VX Heat exchanger.

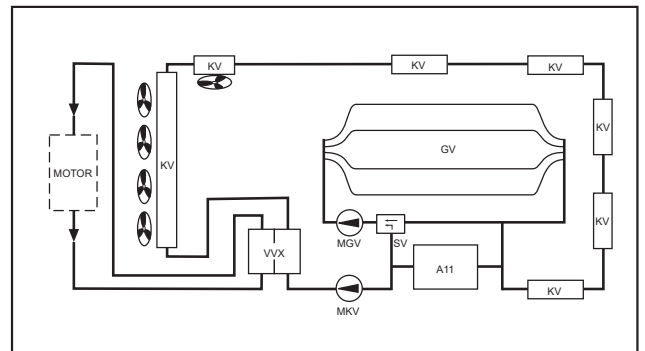

Fully integrated motorhome with AGS II Pro (with shunt valve)

To counteract heat loss and thus maintain a comfortable temperature in the motorhome even during severe cold, the vehicle's walls, floor and roof are insulated.

It is not possible to insulate the motorhome's front as effectively as the rest of the body. Windscreen, side windows and engine bay can all lose heat rapidly. This is also true of safety features in the driver's environment.

Implementing the following suggestions reduces heat loss at the motorhome's front.

- Internally, use blackout curtains at the windscreen/windows at the motorhome's front.
- Externally, use insulating winter covers on the windscreen/windows at the motorhome's front.
- To insulate walls and floor from the engine bay, fit a textile cover on the dashboard.
- Fully integrated motorhomes: use the fans in the dashboard to blow warm air in at the windscreen.

THE BOILER

The motorhome has an ALDE Compact type boiler.

The boiler is used for heating the motorhome and providing hot water.

The boiler has two operating modes:

- 230 V.
- Bottled gas.

If both operating modes are activated on the boiler control panel, electrical operation is prioritised.

Bottled gas operation then starts as required.



The boiler.

The boiler is operated from its own control panel.

The boiler has an integrated water heater that holds 10 litres of water. At a hot water temperature of 70°C, this equates to 15 litres of “tap-hot” water (40°C). The recovery time is around 30 minutes.

The boiler’s hot water temperature can be temporarily raised. A greater volume of water at the desired temperature can then be used.

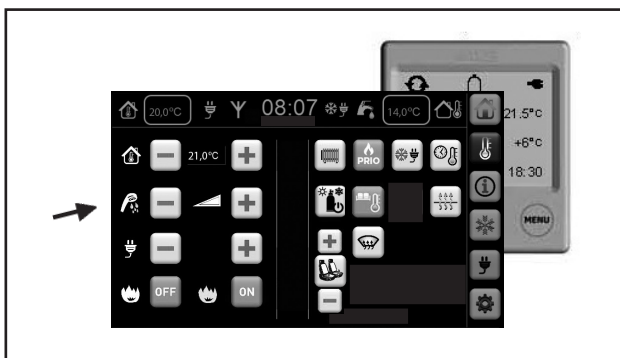

Drain the water heater via the drain valve. This is on the floor, next to the boiler.

The water runs out beneath the motorhome.

The drain valve also serves as a safety valve if there is overpressure in the water heater.

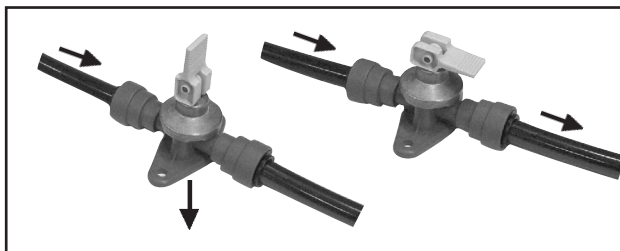

The drain valve for the water heater.
Open and closed positions.

NB!

The water system must always be drained when there is a risk of frost.

Bottled gas operation

When heating using bottled gas, the bottled gas valve must be open.



The boiler takes its combustion air via a suction pipe and releases the exhaust via the chimney on the roof. Combustion is thus entirely screened from the motorhome's interior.

The boiler has a flame failure safety device that automatically cuts off the gas supply if, for any reason, the flame goes out.

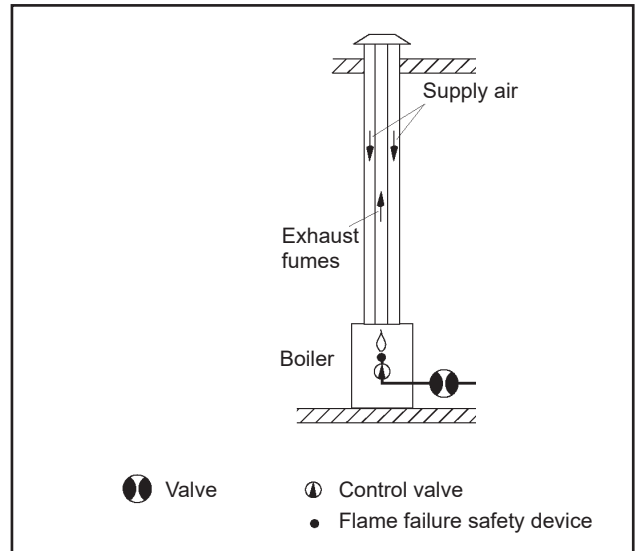

The boiler's bottled gas mode turns off when the engine is started.

Certain motorhomes (certain models) have a crash sensor in the bottled gas system. This enables bottled gas operation while travelling. The boiler's bottled gas mode then continues when the engine is started.

A crash sensor prevents gas leaks in the event of collision or similar. A crash sensor is included in, for example, Duo-control.

(When retrofitting a crash sensor, KABE can change the factory setting so that bottled gas operation continues when the engine is started.)



WARNING!
Fire risk.
If any gas appliance is lit, driving into a petrol station is prohibited.



The boiler's bottled gas mode always turns off when the motorhome's engine is turned off. Bottled gas operation restarts after around 15 minutes.

Electrical operation

The boiler's immersion heater is connected to the 230 V circuit and separately protected by a 16 A circuit breaker.

The boiler's immersion heater has three power modes. Higher power means faster heating, but requires more current. Thus, it must be ensured that the connected power cable can handle this (otherwise, the circuit breaker will trip).

Power mode: 1 kW	Required fuse: 6 A
2 kW	10 A
3 kW	16 A

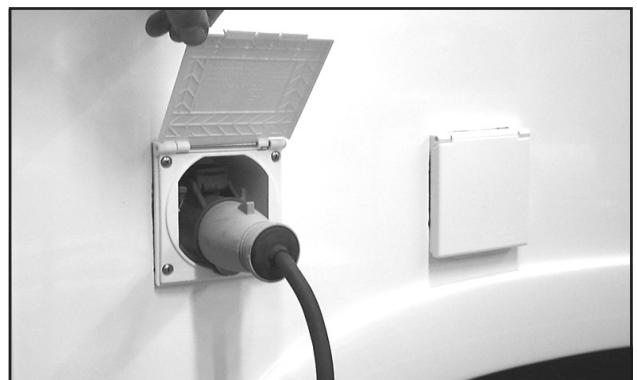

Heating using the immersion heater requires a 230 V supply.

The boiler's control panel

The boiler's control panel is connected to the motorhome's electrical system. Thus, the boiler's most used functions are accessible from the motorhome's control panel (along with other heating system functions).

In normal use, the boiler is controlled from the motorhome's control panel.

The boiler's control panel is unobtrusively sited (e.g. in a wardrobe).

There is a switch next to the boiler's control panel. It is used to set whether the boiler's control panel is:

- connected to the motorhome's electrical system and, consequently, to the motorhome's control panel; or,
- connected directly to the battery.

In normal use, the switch should be in the "System" position.

If the motorhome's electrical system is threatened by interruptions, the boiler can be kept running by putting the switch into the "12 V Battery" position.

For full information of the boiler's various functions, see the separate user instructions from ALDE.

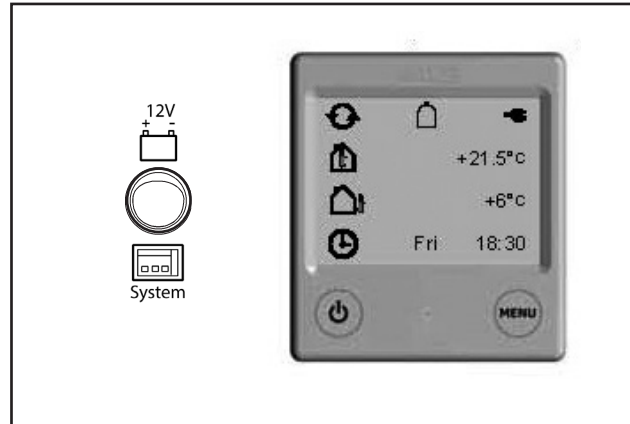

The boiler's control panel.



The motorhome control panel's Heating menu.

Important!

After a power cut, it is approximately 30 seconds before the boiler's automatic ignition can be used.

EXPANSION TANK

The expansion tank is concealed by a cover plate. Fluid levels in the tank can be read through the cover plate's inspection hole.

The expansion tank serves to accommodate the variations in fluid level due to the heating system's temperature. The fluid expands as the system heats up and gives tank levels that are higher than when the system is cold.

The fluid level in the expansion tank must be within the markings.

Too little fluid in the heating system may lead to breakdowns and/or damage to the circulation pump.

Too much fluid in the system may lead to overflows when the system heats up.

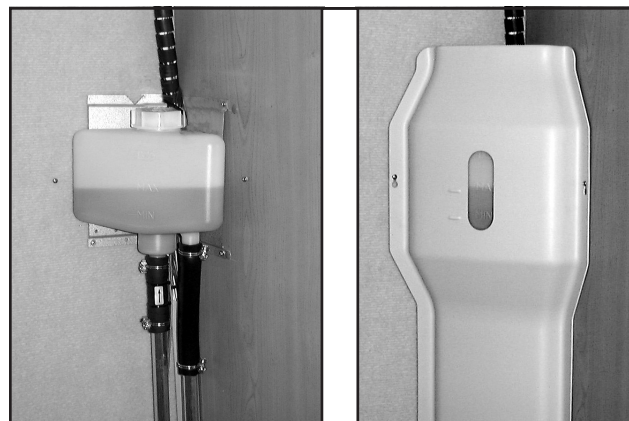

The expansion tank and cover plate with inspection hole.

HEATING SYSTEM FLUID

A mixture of water and glycol is used in the heating system and the boiler.

Using the right type of glycol is important for protecting the heating system from corrosion (and thus avoiding leaks in the future).

The right mixture ratios are critical for protecting against freezing at low temperatures.

Glycol goes off and must be changed to ensure its full effect. Intervals for changing depend on the type of glycol used. Certain types of glycol have to be changed every two years. Long-life glycol provides full protection for up to five years. Ensure that glycol changes are documented in the service book.

Use only glycol that is recommended by KABE.

Filling

Remove the cover plate in front of the expansion tank.

Fill the system so that, with a cold boiler, the level is just above MIN.

Refit the cap and the cover plate.

Draining

Draining is by using a pair of pliers to remove the drain plug (under the floor). Also remove the expansion tank's cap.

NB!

Never mix different types of glycol. This can cause chemical reactions that damage the heating system.

Recommended glycol products

Use (mono) ethylene glycol with a corrosion inhibitor. This is tested as per the SAE J 1034 quality standard. Long-life products have to satisfy the requirements of G12++.

Examples of products satisfying the requirements:
Alde Premium G12++ Antifreeze (long-life, 5 years).

Regularly check the heating system to ensure that there are no leaks at any of the joints in the heating loop. If glycol has leaked out, rinse carefully with water and then dry.

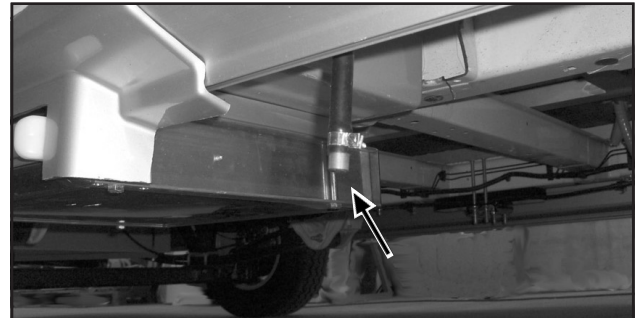

Drain plugs for draining the heating system. Accessible under the motorhome (by the boiler and at the heating system's lowest point).

CONVECTOR SYSTEM

Convectors are mounted on the walls. Heat is transferred to the air as it passes around the convector fins.

Between the convectors, the heating system's fluid is led via hoses and pipes. Some of these have bleed nipples. Air in the heating system prevents the fluid from circulating correctly. This user manual contains instructions for bleeding the system.

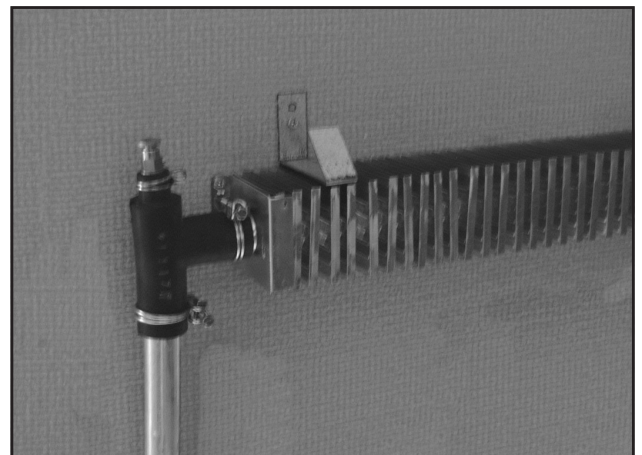

Convector and hose connection with bleed nipple.

HEATING LOOPS IN THE FLOOR

Heating system fluid circulates through heating loops built into the living area's floor.

Depending on motorhome model, floor heating is regulated in various ways.

- AGS II floor heating is integrated with the convector system.
- AGS II Pro floor heating has its own heating circuit.

Floor heating for each model is described below.



WARNING!
Risk of leaks if the heating loops are damaged.
Never screw or nail into the floor.
This can create leaks in the floor's in-built heating loops.

Heating system with integrated AGS II floor heating

With integrated floor heating, the temperature of the floor system is the same as that of the rest of the heating system.

Heat from the boiler is distributed to the convectors and floor heating.

The temperature in the motorhome is monitored by the heating system's control panel.

As necessary, the temperature of the convectors and floor heating rises or falls.

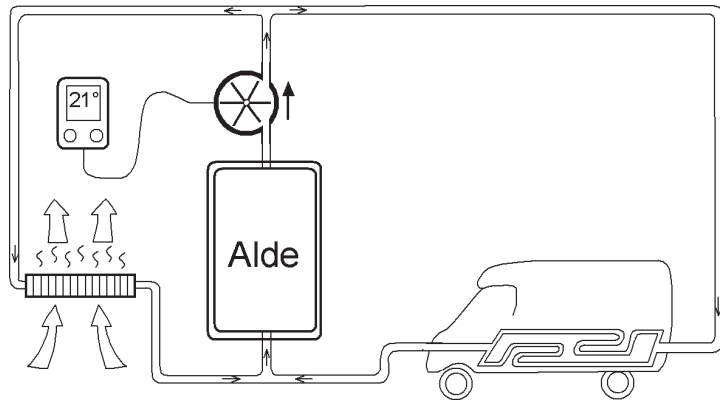

The convectors heat the air, which then rises along the walls.

Floor heating temperature is the same as that of the rest of the heating system.

Descriptions

Heating system with AGS II Pro floor heating

AGS II Pro floor heating is recognisable from the shunt valve by the boiler.

There is a separate heating system for the convectors and another for floor heating.

The convectors

The temperature in the motorhome is monitored by the heating system's control panel. As necessary, the temperature of the convectors rises or falls.

AGS II Pro floor heating

Start the floor heating via the heating system's control panel (the circulation pump icon). The shunt valve maintains the even temperature of the floor.

On the control panel, set the desired indoor temperature.

Adjust the floor heating's shunt valve so that the motorhome's floor is pleasantly warm.

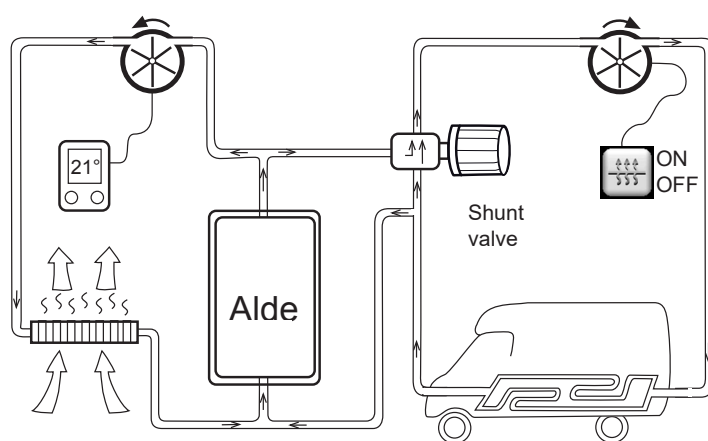

The convectors heat the air, which then rises along the walls.



ZONE HEAT

Certain models have zone heating. (KABE Imperial)

With zone heating, the temperatures of zones 1 and 2 can be set individually.

- Zone 1 is the front part of the motorhome (lounge seating).
- Zone 2 is the rear part of the motorhome (bed).

On the control panel, set the desired temperature.

The toilet and shower space is warmed by the common return loop. Thus, the temperature here is a little higher than in the rest of the motorhome.

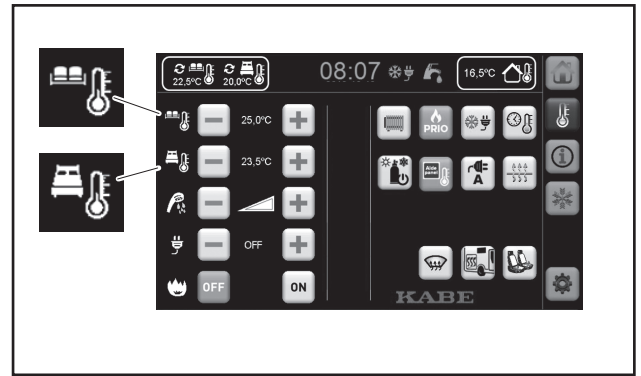

Zone heating: different temperatures for lounge seating and bed areas.

WINDSCREEN HEATING

While travelling, all models have windscreen heating.

Models with a large windscreen (fully integrated motorhomes) have windscreen heating via the living area's heating system. A separate fan can increase air flow by the windscreen (J).

While travelling, the fan can be started via a switch (K) on the dashboard.

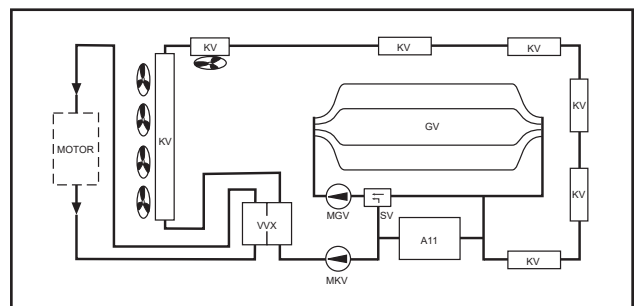
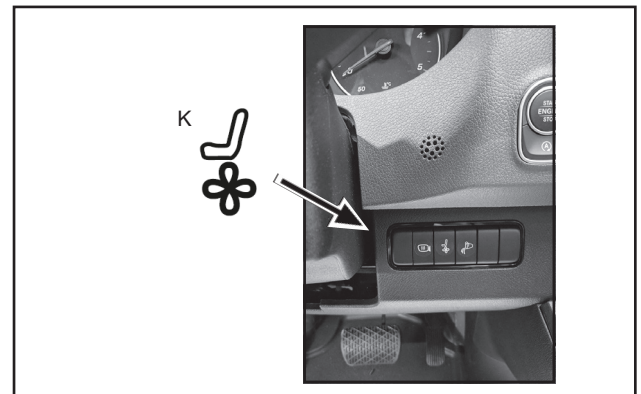
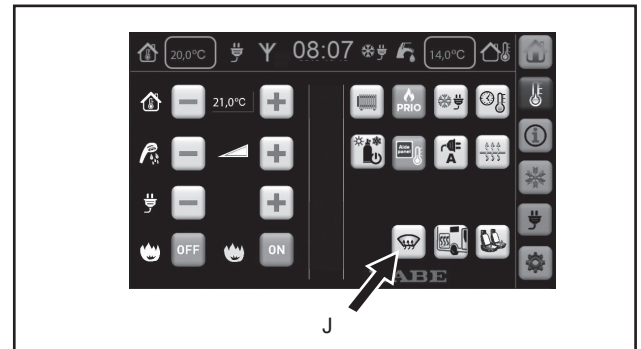

WINTER CONNECTION (MOUNTAIN CONNECTION)

In winter connection, the boiler starts when a 230 V supply is connected to the motorhome.

See section 3, "Use".

VENTILATION

FIXED VENTILATION

The motorhome's ventilation satisfies standard EN 721 on safety requirements for ventilation in recreational vehicles. The ventilation has been tested for the number of people and the uses for which the motorhome is intended.

Thus, the fixed ventilation must not be altered!

The air in the motorhome is ventilated to the outside by:

- fixed ventilators in the roof (Elektrolux ventilators),
- ventilating roof hatches,
- kitchen ventilation.

Ensure that the motorhome's fixed ventilation is not obstructed. In winter, roof hatches and ventilators must be kept free from snow.

In especially unfavourable weather, moisture can penetrate the fixed ventilation in the roof hatches. Protect the motorhome's furnishings.

NB!

In snow storms or other especially unfavourable weather, furnishings should be protected against damp or snow penetrating through the motorhome's fixed ventilation.

ROOF HATCHES

Roof hatches and roof lights must be closed and bolted throughout travel. Blackout curtains and mosquito screens must be fully raised throughout travel because they can be damaged by vibration and increased ventilation.

KITCHEN VENTILATION

Each Travel Master has a motor-driven extractor fan fitted to the ceiling. The switch is on the fan panel below the crockery cupboard. The switch for kitchen lighting is also here.

The fan filter

This filter absorbs the fat in cooking fumes and must be cleaned from time to time. Clearly enough, the frequency depends on the foods that are cooked and how often the fan is used. Wait until the suction generated by the fan lessens.

Clean with hot water to which some synthetic cleaning agent has been added.

The fan impeller

Fan impeller and motor are accessed for cleaning by unscrewing the connection to the ceiling.

CONDENSATION

Condensation occurs naturally when warm air hits a cold surface (e.g. the interior side of a window and pane surfaces inside double glazing).

Condensation formation is affected by a number of factors, for example:

- The temperature difference between inside the motorhome and outside the window.
- The weather. High air humidity or mist means that the air inside the motorhome contains more water.
- Number of people (or pets) in the motorhome.
- Activities in the motorhome (e.g. cooking).

If the weather and activities are such that there is a lot of condensation, the latter can be combated by:

- Airing the motorhome so that the air inside contains as little water as possible.
For efficient airing, open the roof hatch.
Ensure that the motorhome's fixed ventilation is not impeded (e.g. no cushions or loads obstructing ventilation routes).
- Raise the temperature in the motorhome.
Raising the temperature in the motorhome increases air flow in the ventilation. Furthermore, the interior side of glazing warms up, which also further combats condensation.

When condensation forms on cold surfaces, it should be wiped away.

The motorhome's windows are made of an acrylic plastic. Water vapour can slowly migrate through the acrylic plastic and lead to condensation forming between the panes. This is natural and the condensation disappears after a while when it has migrated further.

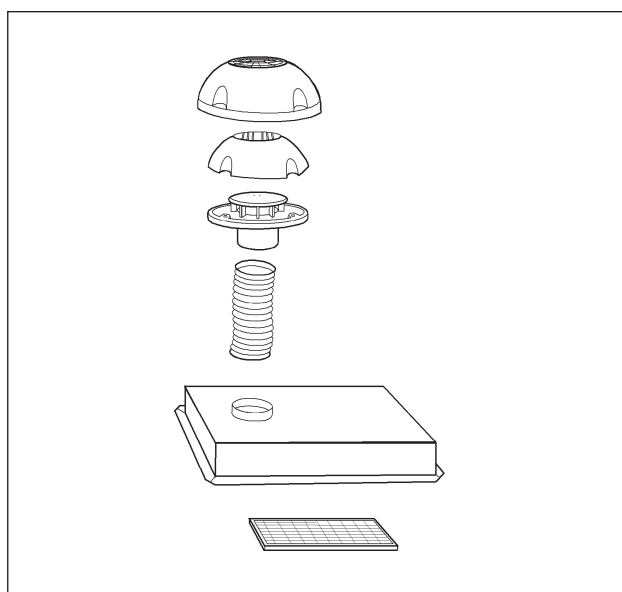

The kitchen fan.

AIRVENT

AirVent increases ventilation in the motorhome. The purpose is to cool the motorhome on hot summer days.

AirVent comprises:

- a fan mounted in a ceiling hatch,
- a thermostat that cuts power to the fan when the temperature is below a set value.

Thus, when the fan is on, it will start/stop depending on temperature changes.

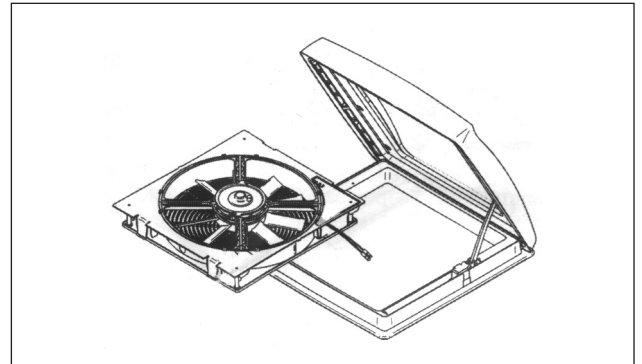

In the ON position, the thermostat is active. The thermostat can be adjusted from 5 to 30°C. Ensure that the fan is switched on and correctly set.

The fan can be used manually. For continuous operation, set the thermostat to the OFF position. This disconnects its temperature sensing function.



The fan can be set at several speeds in each “direction”.

AirVent is most effective when doors and windows are shut so that cool air from the shade beneath the caravan/ motorhome is sucked in through the floor’s standard ventilation openings.

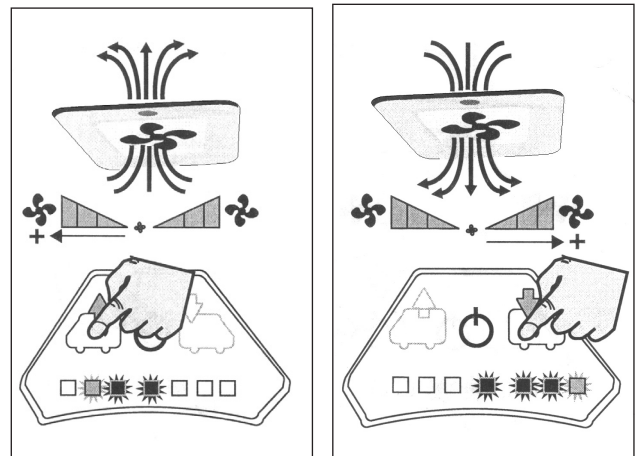

AIR CONDITIONING (AC)

Certain motorhomes have factory-fitted AC. (Factory-fitted option for others.)

For use and maintenance, see the manufacturer’s instructions.

Factory-fitted AC can be controlled from the motorhome’s control panel. This means that the motorhome’s electrical system communicates with the AC.

If the AC is entirely switched off (no power), there can be no communication. The motorhome’s electrical system here shows a fault message on the control panel.

To avoid this fault message on the control panel, leave the AC in Standby mode.

WATER/WASTE WATER SYSTEMS

FRESH WATER SYSTEM

The fresh water tank is in the sofa. Consequently, the tank has a frost-free location when the motorhome is heated.

The water level in the fresh water tank can be read on the motorhome's control panel.

Filling with fresh water is via a filler pipe that is accessible from the outside. The filler pipe's cap is lockable.

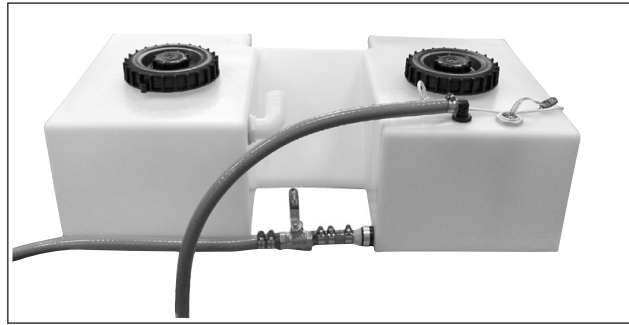

The fresh water tank.

NB!
Remember that fresh water is perishable!
Ensure that the water in the tank is always fresh.



Filling with fresh water

Descriptions

From the fresh water tank, water is pumped to the kitchen, hand basin, shower, toilet and water heater. The hoses in the water system are of "foodstuffs quality".

The water pump is in the fresh water tank. In the water taps, there are switches that start the water pump when the taps are turned on.



The water pump.

So that the water pump can start, the water pump must be activated on the motorhome's control panel.

The water pump should be deactivated throughout travel and when the motorhome is left unattended.

The motorhome's hot water is fresh water that has been heated in the boiler's water heater. Thus, hot water and cold water are pumped by the same pump. To heat water, the boiler must be on. See also the boiler description.

Especially after long periods of disuse, always flush out the water heater before using it. When it is in continuous use, the water heater must be drained around once a month. This is to renew the air cushion in the heater.

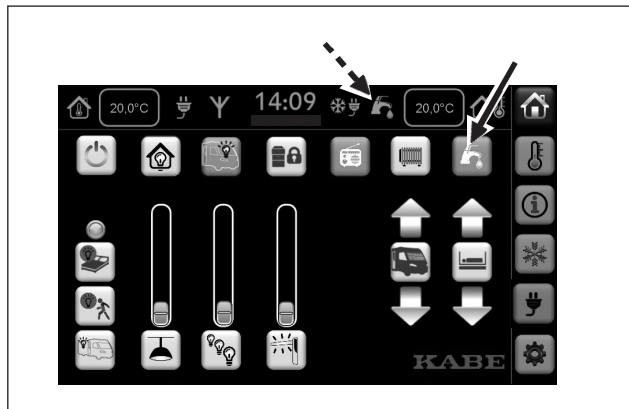

This icon shows that the water pump has been activated.

Drain the fresh water tank by pressing the icon on the control panel. An electrically controlled valve opens the outlet. The water runs out beneath the motorhome.

Close the valve by pressing the control panel's icon again.

For water to be able to run out of the system, the water taps in the motorhome must be open. This enables air to be sucked into the water lines as the water (both hot and cold) drains.

The fresh water tank must be cleaned occasionally. To clean the tank's interior, unscrew the two caps on the tank's top. Clean with washing-up liquid and scour with a dish brush. Before refilling the tank with fresh water, rinse it out and flush out the water lines.

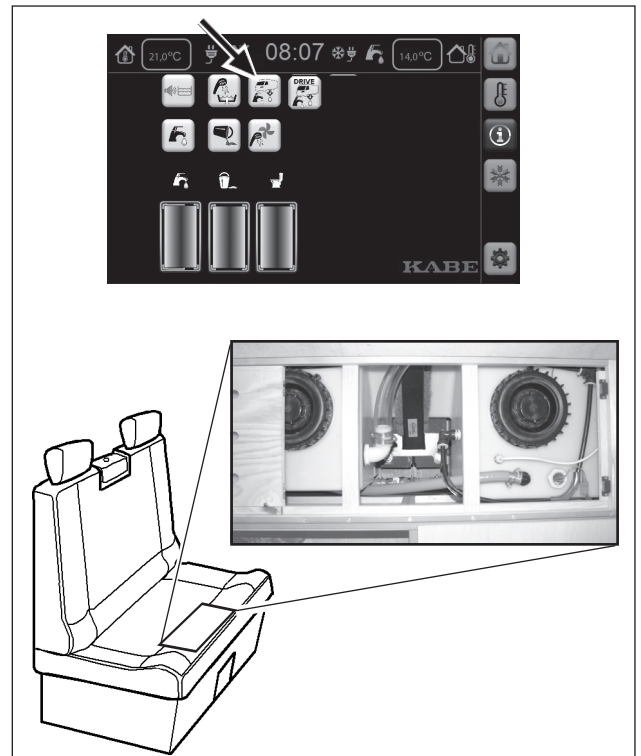

Draining the fresh water tank.

The water heater is drained via a separate drain valve located next to the boiler. Water runs out beneath the motorhome. See also the boiler description.

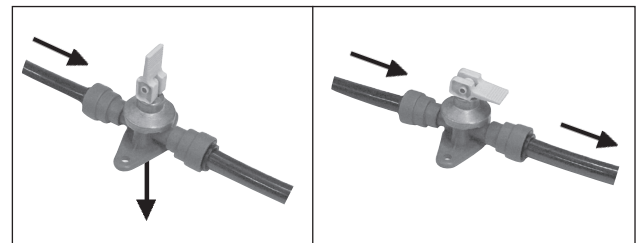

Drain valve for the water heater.
Open and closed positions.

The picture shows an electrically controlled valve.

The line in the indication window (A) shows the valve's status.

A1 The valve is open. (The line runs in the same direction as the hose.)

A2 The valve is closed.

The valve can be manually operated using the knob (B).

Pull the knob up and turn several times until the line shows the desired status.

After manual operation, push the knob back down.

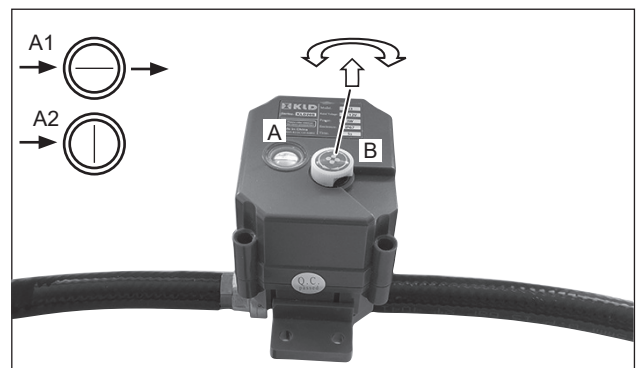

Electric drain valve.

Fresh water tank volume:

- Royal: 20/90 litres.
- Crown: 20/150 litres.
- Imperial: 20/150 litres
- Van: 20/83 litres.

Ahead of travel, a “drive mode” can be selected. This reduces the volume of water to around 20 litres. These 20 litres are included in the motorhome’s weight.

When the water tank has more than 20 litres, the extra content is to be calculated as load.

Select drive mode by pressing the icon on the control panel. Water will then run out beneath the motorhome until around 20 litres remain in the tank.

When the motorhome’s engine is started, the electrical system measures the water volume in the tank. An audible signal is given if there are more than 20 litres in the tank.

The control panel shows the “Information” menu.

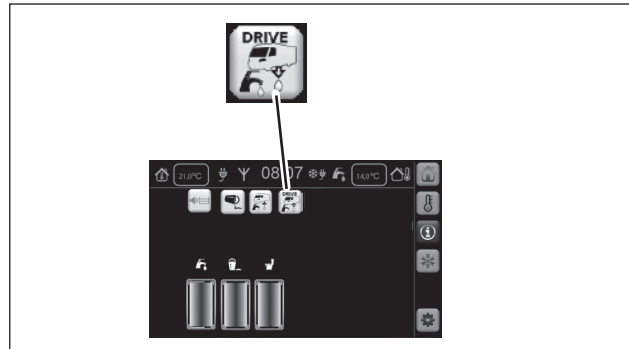
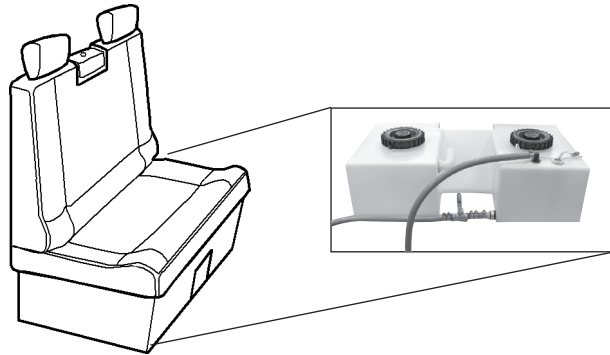

Select drive mode on the control panel. Water runs out beneath the motorhome until around 20 litres remain.

NB!

The extra water volume is part of the motorhome’s load. Take care not to exceed the motorhome’s total permitted weight.

Measurement of the water volume in the tank can be affected if the motorhome is leaning.

When there is a risk of freezing, the water system must be drained as per the manual’s instructions.

When cleaning the fresh water tank, the overflow hose must also be flushed through.

Water purifier

As a factory-fitted option, certain motorhomes have an Alde AquaClear water purifier.

This disinfects and filters the water from the fresh water tank.

The water purifier has two parts:

- A UV unit (A) that disinfects the water by exposing it to ultraviolet light.
(Alde AquaClear UV-C, 3030031)
- A carbon filter (B) through which the water passes.
(Alde Water Carbon filter, 3030032)

The carbon filter must be changed once a year.

The UV unit (A) must be changed after 300 hours of active use (i.e. the ultraviolet light has been on).

Active time is recorded by the electronics. Remaining active time is shown on the control panel.

When no active time remains, a message is shown on the control panel. Fit a new UV unit and then press Reset. The control panel will then show a remaining active time of 300 hours.

When there is a risk of temperatures below zero degrees Celsius, the entire water purifier must be removed and kept somewhere frost-free.

When the water purifier has been removed, it should be replaced with the corresponding connection hose (C) supplied with the motorhome.

When refitting the water purifier's units, it is essential to install them in the right order. The water must flow first through the UV unit (A) and then the carbon filter (B).

It is also vital to fit the units sloping upwards in the direction of the water flow. This allows air in the water system to pass the units.

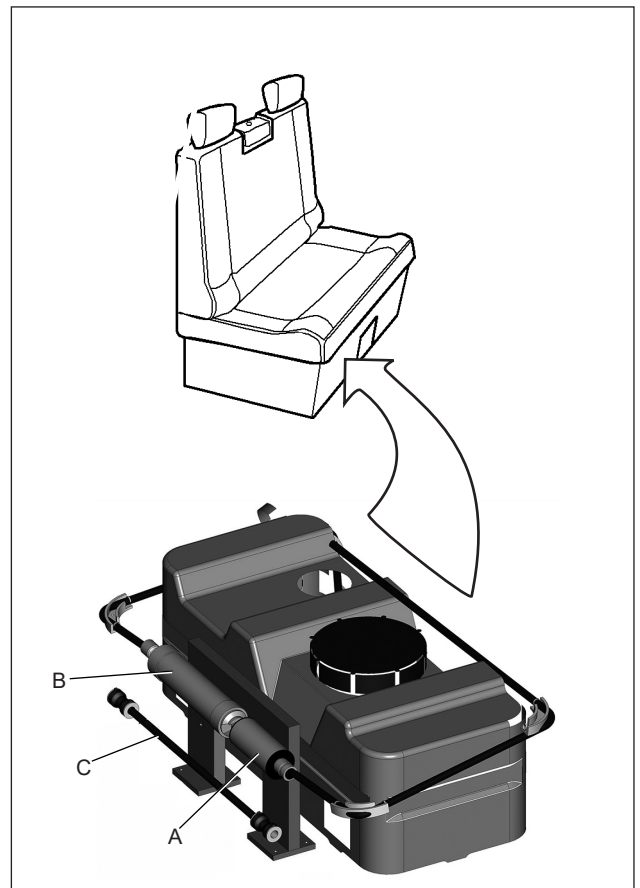

The water purifier is mounted at the fresh water tank.

NB!

Freezing can destroy the water purifier.

Drain the water system when the motorhome is not heated and there is a risk of temperatures below zero degrees Celsius.

The water purifier's units must be removed and kept somewhere frost-free.

See also the manufacturer's user instructions for full details of use and maintenance.

GREY WATER SYSTEM

Grey water is waste water from the kitchen sink, hand basin and shower.

The grey water tank is plastic and mounted in a protective, insulated box. When the motorhome's heating is running, the grey water tank is frost-free.

The grey water tank is in the living area's floor toward the back of the motorhome.

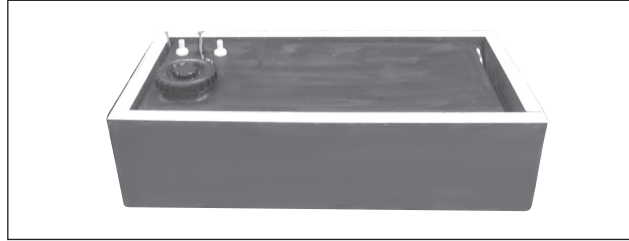

The grey water tank.



The grey water tank is mounted close to the motorhome's rear axle.

Drain the grey water tank by pumping it with the drain pump. The location of this pump varies with motorhome model.

Drain the grey water tank by starting the drain pump via the switch (A). The drain pump can also be started via the control panel's Information menu (B).

The drain pump can only be used when the vehicle's engine is turned off.

Collect the grey water in a suitable receptacle and empty it into a standard toilet or other approved emptying facility.

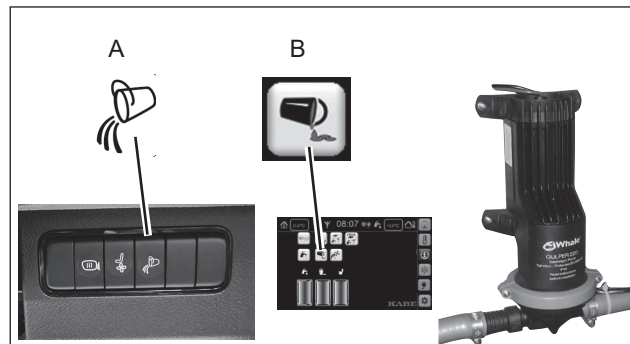

The grey water tank's drain pump and its switch.

To avoid odours, the grey water tank should be cleaned once a month. Odours are more likely in hot weather than they are in cold weather.

Clean the grey water tank by flushing out sludge and sediments that collect on the tank's bottom.

The grey water tank's base plug is rubber and expands when the handle is swung downward. Remove the base plug by raising the handle and pulling straight up.

Instructions for draining and cleaning are given in the "Use" section.

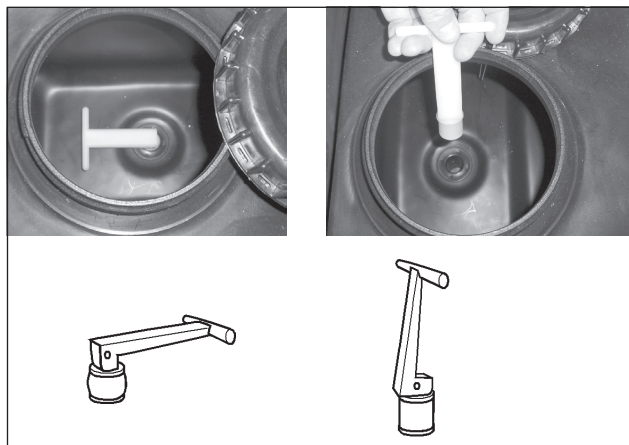

The grey water tank's base plug.

Under the influence of gravity, grey water from the kitchen and the hand basin runs into the grey water tank.

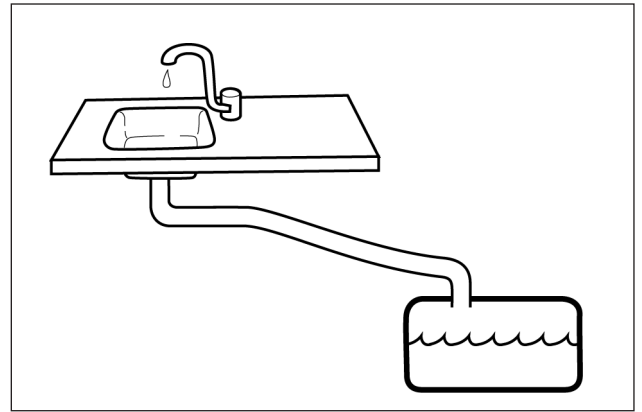

Grey water from kitchen and hand basin.

In certain models, a separate pump pumps water from the shower floor into the grey water tank. The pump operates when the shower is being used. Turning off the shower also switches off the pump, but with a delay so that all the water is pumped out.

The outlet in the shower floor cannot be fully drained by the shower's pump. A small volume of water remains in the outlet. If there is a risk of frost, the shower's outlet must be protected by pouring an antifreeze agent into it.

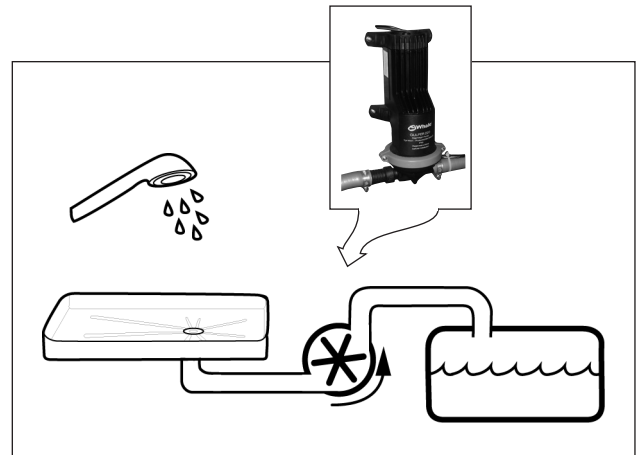

The shower's grey water pump.

NB!

Alcohol will damage the shower floor.

Alcohol-containing antifreeze must be immediately flushed from the shower floor with water.



The pump in the shower's outlet can be operated manually via a button on the motorhome's control panel.

RISK OF FREEZING

To avoid damage due to freezing, the water/waste water system must be completely drained if the motorhome is to be left unheated in sub-zero temperatures.

Ensure that the following components are drained:

- fresh water tank,
- water pump,
- water heater,
- mixer taps,
- grey water tank,
- shower hose
(where relevant, shower in luggage compartment also),
- shower outlet,
- toilet.

Leave all the water taps and drain cocks in the open position. So that both cold and hot water are ventilated, water taps must be in the lukewarm position.

Important!

The guarantee does not cover water system components that break because of frost or freezing.

TOILETS

Different KABE Travel Master models have different toilets.

- Cinderella Motion incinerating toilet (certain models only or factory-fitted option).
- Thetford C263 cassette toilet

CINDERELLA MOTION INCINERATING TOILET

This toilet is intended solely for human waste and toilet paper.

Use the toilet's purpose-designed paper bags. Use a new paper bag at each visit.

After visiting the toilet, "flush" by pressing the start button.

Before incineration can start, the paper bag must fall into the ash bowl. If the bag is light, there is a risk that it will not fall correctly. If necessary, bag weight can be increased by pouring in a little water.

For the periodic burning of waste, the incinerating toilet uses bottled gas. Ensure that bottled gas is available and that the supply valves to the toilet are open.

Incineration also requires functioning electrics. The motorhome's 12 V supply must be available throughout incineration.

Incinerating the toilet's waste takes around 1 – 2 hours. For incineration to work, the toilet lid must be down.

Even if incineration is not finished, the toilet can be used again. Incineration is interrupted when the lid is raised. There is no incineration when the toilet is in use.

Incineration resumes when the start button is pressed.

Status indication is given on the toilet's panel.

- Green is normal.
- Yellow is incineration in progress.
- Red is a function fault.

The toilet's incineration function requires fully functioning ventilation. Ensure that both air intake and exhaust ventilation are clear. For example, snow must not impede toilet ventilation. If necessary, a chimney extension can be fitted. A chimney extension must not be in place during travel.

The toilet must be maintained as per the manufacturer's instructions. Recommended intervals:

- Empty the ash bowl at least once a week.
- Clean the ash bowl at each third emptying.
- Clean the catalyst as per instructions.

See the manufacturer's user instructions for full details of use and maintenance.

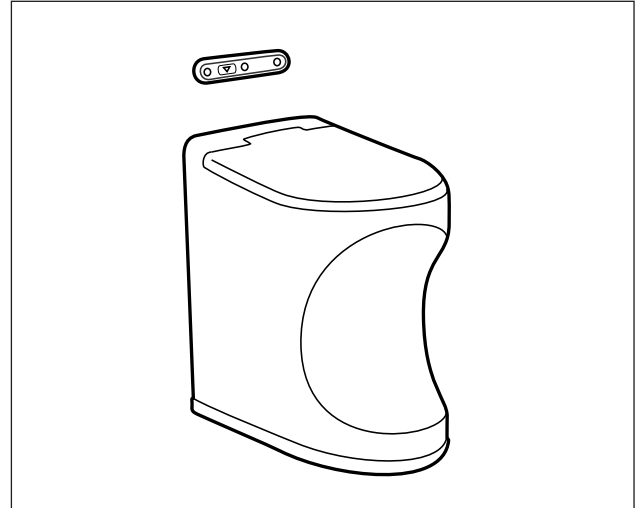

WARNING!

This toilet is intended solely for human waste and toilet paper.

Incineration of other materials can present risks.

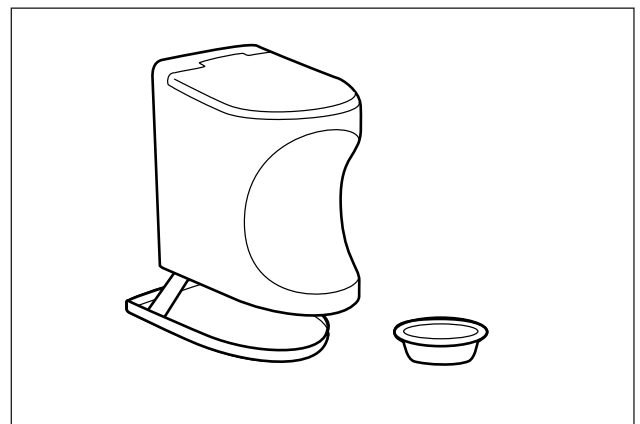

THETFORD C263 TOILET

Preparing for use

Before using the toilet, add around 2 litres of water so that the tank's bottom is covered. Then add sanitary fluid via the emptying spout (not via the toilet bowl).

Sanitary fluid can be bought from KABE distributors.

When the toilet's tank is almost full, the level light next to the flush button comes on.

Empty the tank before the level light comes on.

Using the toilet

When using the toilet:

1. Turn the toilet stool to the desired position.
2. Pull the lever that opens the toilet's valve blade.
3. After use, flush the toilet clean by pushing the flush button. Provided that the "WATER PUMP" switch on the motorhome's control panel is in the "ON" position, water will then be pumped from the fresh water tank.
4. Close the toilet's valve blade.

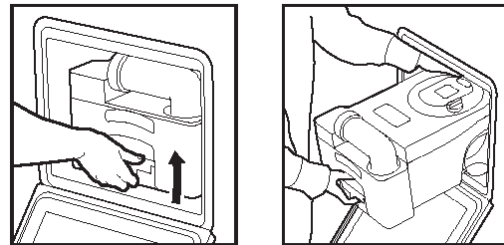
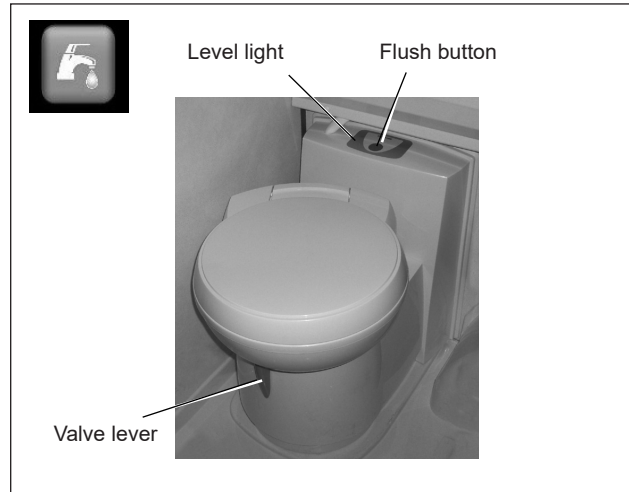

Emptying the tank

When emptying the toilet:

1. Close the toilet's valve blade.
2. Pull out the waste tank as per the picture on the right.
3. Carry the waste tank by its handle. Turn the emptying spout so that it points upward while the tank is being carried (see picture).
4. Empty the waste tank into a standard toilet or other approved emptying facility. Press the air valve (see picture). Do not press the air valve before the emptying spout is pointing downward.

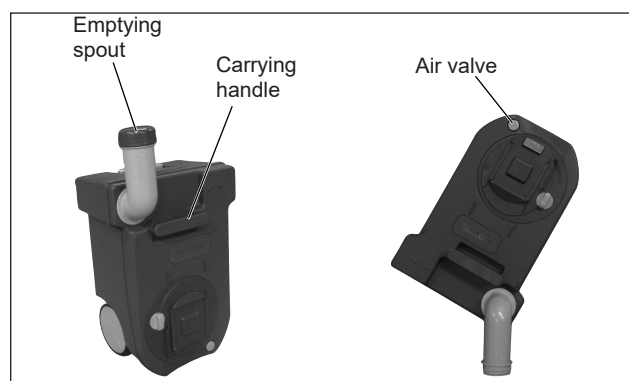
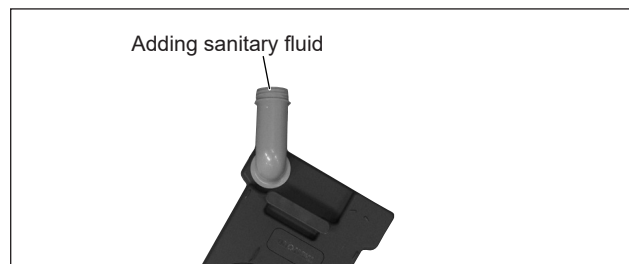

Important!

Do not press the air valve before the emptying spout is pointing downward.

Cleaning

To maintain proper working order, it is important to clean the toilet and the waste tank.

Use only recommended cleaning agents. Avoid household products. These may contain solvents that could damage the toilet's seals and other components.

For cleaning and maintenance, see also the manufacturer's use and care instructions.

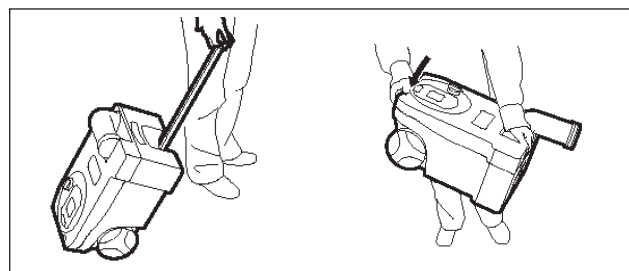

ELECTRICAL SYSTEM

The electrical system in the KABE Travel Master is made up of three separate systems:

- The 230 V AC electrical system.
Used for the boiler's immersion heater, the refrigerator and the battery charger.
- The living area's 12 V system.
Used for most electrical functions in the living area, e.g. lighting, water pumps and refrigerator.
- The vehicle's 12 V system. Used for running lights, starter motor and other electrical functions relating to the vehicle and travel. See the vehicle's user manual.

THE 230 V AC ELECTRICAL SYSTEM

The 230 V AC electrical system is used for the boiler's immersion heater, circulation pumps, refrigerator and battery charger.

The highest permitted power load is 3,600 W (16 A).

The 230 V AC system is energised by connecting an earthed power cable to the motorhome's junction box. The power cable must be approved for outdoor use and power loads of 3,600 W (16 A).

(Cable's cross section: at least 2.5 mm².)

Connect the power cable to an earthed socket.

KABE recommends power cables with an in-built residual current device.

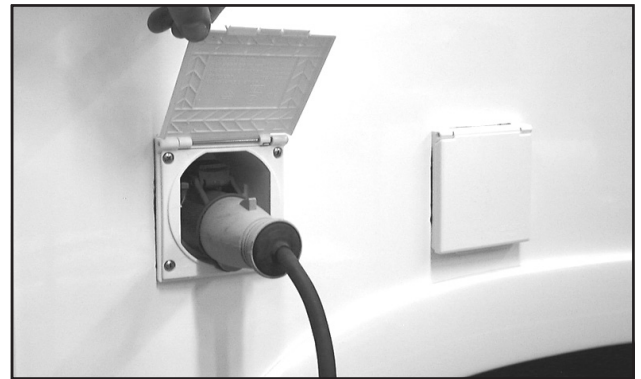

230 V AC connection.



WARNING!

Risk of injuries.
Use a power cable that is approved for outdoor use.
Site the cable away from all risk of damage.
Damaged cables must be replaced.

If there is a voltage drop, the motorhome's electrical equipment may not function satisfactorily.

The longer the supply cable, the greater the voltage drop. See the tables for the voltage drops with different lengths of cable.

At camping sites, the incoming supply may be affected by drops that bring the voltage down to as low as 180 – 190 V (especially in winter when the loading is high).

10A	10m	20m	30m	40m	50m
1,5 mm ²	2,2V	4,4V	6,6V	8,8V	11V
2,5 mm ²	1,4V	2,7V	2,8V	5,4V	7V

Voltage drops in cables, 10 A load.

15A	10m	20m	30m	40m	50m
1,5 mm ²	3,3V	6,6V	9,9V	13,2V	16,5V
2,5 mm ²	2V	4V	6V	8V	10V

Voltage drops in cables, 15 A load

If the power cable is kept in a reel, it must be fully unwound before connection. A cable on a cable reel functions as an electrical coil. This results in heating and power loss (voltage drop) in the reel. The cable gets very hot when power consumption is high.

Pay attention also to ensuring that the cable is not exposed to damage and that the plug is securely connected.

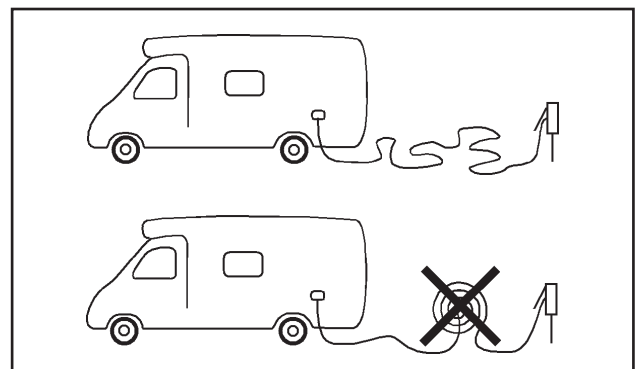

Coiled cables must be fully unwound.

12 V TO 230 V INVERTER

Certain models have an inverter (factory-fitted option for others).

An inverter converts the battery's 12 V to 230 V alternating current. Thus, 230 V is available from the motorhome's power outlets even when the motorhome is not connected to the mains.

The inverter is powered by the living area's battery.

Using 230 V from the inverter loads the battery. Battery charge drops rapidly when using 230 V from the inverter.

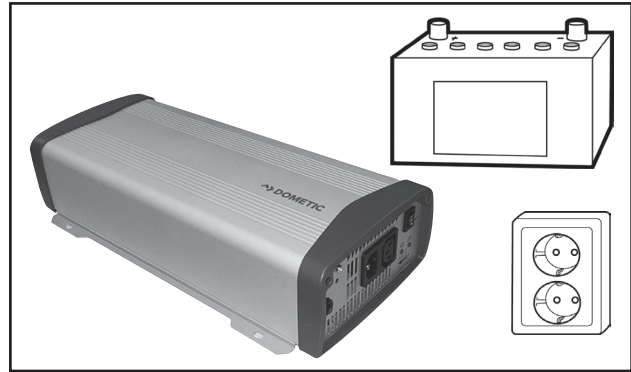

Inverter

When the motorhome is connected to the mains, the inverter uses the available 230 V. The battery is not loaded. All the motorhome's power outlets are then connected to the mains.

The inverter is started and stopped from the motorhome's control panel.

To save battery charge, switch off the inverter when it is not in use (even if 230 V is not being used).

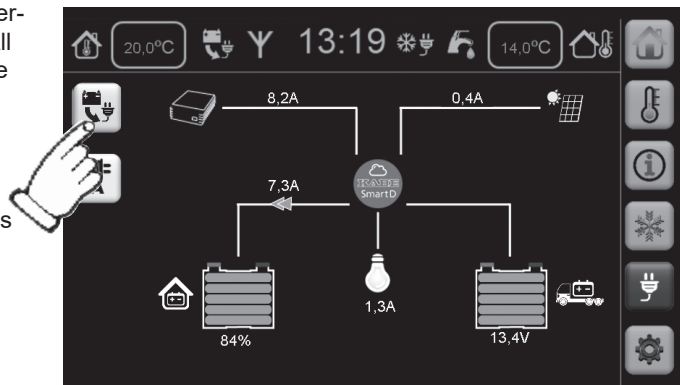

Starting and stopping the inverter from the control panel.

The inverter's maximum power output is 1,800 W. The greater the power use, the quicker the drop in battery charge.

If the battery charge drops too low, the inverter switches off automatically. The battery then needs charging.

If the inverter gets too hot, it switches off automatically. Ensure that the inverter's ventilation is not obstructed.

If too great a load is presented to the inverter, a circuit breaker on the inverter trips. Power outlets will then be dead, even if the motorhome is connected to the mains. Reset the breaker by pressing the Breaker button on the inverter.

Bear in mind that some appliances require a lot of power when starting.

A residual current device is mounted next to the inverter's 230 V outlet. This means that the motorhome has two residual current devices when connected to the mains.



A residual current device is mounted next to the inverter.

The motorhome's refrigerator and boiler are not connected to the inverter. The refrigerator and boiler can only be powered from the 230 V supply when the motorhome is connected to the mains.

For further information, see the manufacturer's instructions.

MAIN POWER SWITCH, 12 V SYSTEM

The living area's 12 V system has a main power switch with a key.

This main power switch cuts the supply from the battery. This de-energises all the living area's functions.

When the motorhome is not being used, turn the main power switch off. This saves the battery and thus reduces the risk of it running flat.

When the main power switch is turned on, the electrical system begins a start-up procedure that takes a few moments. The living area's electrical functions cannot be used before completion of the start-up procedure.

If the motorhome is connected to 230 V, the living area's battery and the vehicle's starter battery will be charged even if the main power switch is off.



ALARM ON ENGINE START

The electrical system gives an alarm if the engine is started while:

- 230 V AC is connected; or,
- the antenna is in the extended position.

There is an audible alarm and the corresponding alarm icon shows on the control panel.

GENERAL TECHNICAL DESCRIPTION OF THE LIVING AREA'S 12 V SYSTEM

The living area's 12 V system is based on "Smart D", an advanced electronic system.

The control panel shows current information for the system. The control panel's display is touch-sensitive. Pressing the control panel's icons (buttons) sends instructions to the system.

"Smart D" is a BUS system. This means that electrical functions are controlled by the system's software. The software's electronics are integrated into the control panel (M).

The system's software communicates with a number of outputs and inputs at various points in the motorhome. The electronic units with inputs and outputs are designated N1 – N6. (N1 – N5 in certain models.)

Power consumers (lights, pumps, etc.) are connected to outputs. Thus, the system can start any power consumer connected to a particular output. (A)

Most switches in the living area are connected to inputs. The software reads the inputs and, consequently, switch status. The system implements the action associated with the switch. (Example A)

Example A:
Turning on a light. Press the switch. From the input, the software reads that the switch has been activated. The software commands the output to send power to the light. The light comes on.

At several points in the motorhome, there are switches connected traditionally to consumers. Here, the switch makes or breaks the power circuit between output and consumer. (Example B)

Example B:

- With the switch in the off position, the connection is broken. The software cannot turn the consumer on.
- With the switch in the on position, the software can control whether the consumer should be on or off.

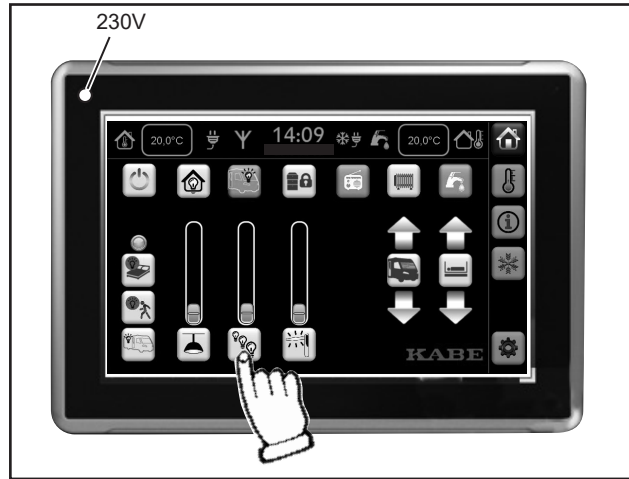

Control panel (M).

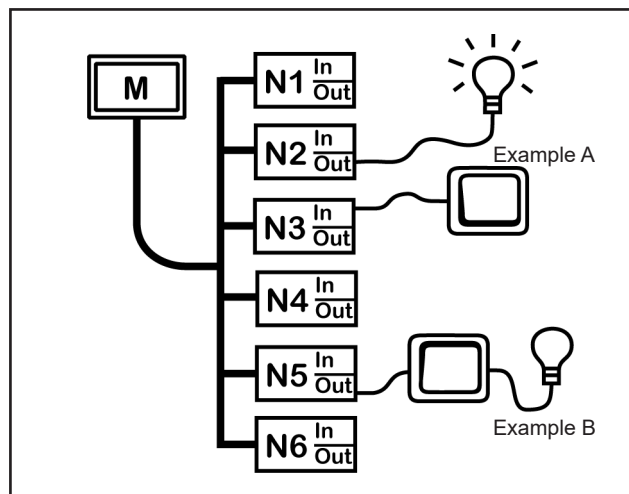

The BUS system has electrical inputs and outputs (N1 – N6) on various units.



The BUS system's N1 unit is a: Dometic Smart D 12 V Distribution Box.



The BUS system's N2 – N6 units are: Dometic Smart D I/O cards.

CONTROL PANEL

The control panel's menus are described below.

The manual describes all possible functions.

The motorhome's control panel shows only available functions.

Control panel illumination

The control panel goes out after a few seconds with no contact.

A quick touch restores illumination.

Status bar

The status bar at the top of the control panel shows current values (current status) and any alarms.

Information in the status bar is displayed in the same way whichever menu is selected.

The following information is shown in the status bar:

- A Temperature inside the motorhome.
- B Icon for TV antenna up.
- C Icon for 230 V connected.
- D Time and date.
- E Icon for Winter connection set.
- F Icon for Water pump selected.
- G Outside temperature.

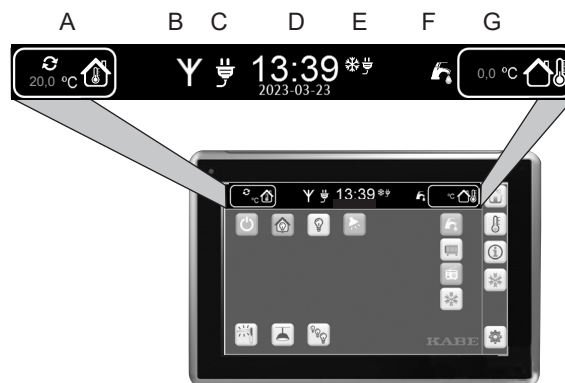

Menu selection

Use the menu buttons to select which menu the control panel is to display.

Each menu makes a number of functions available via buttons that can be pushed.

Each menu is described below.

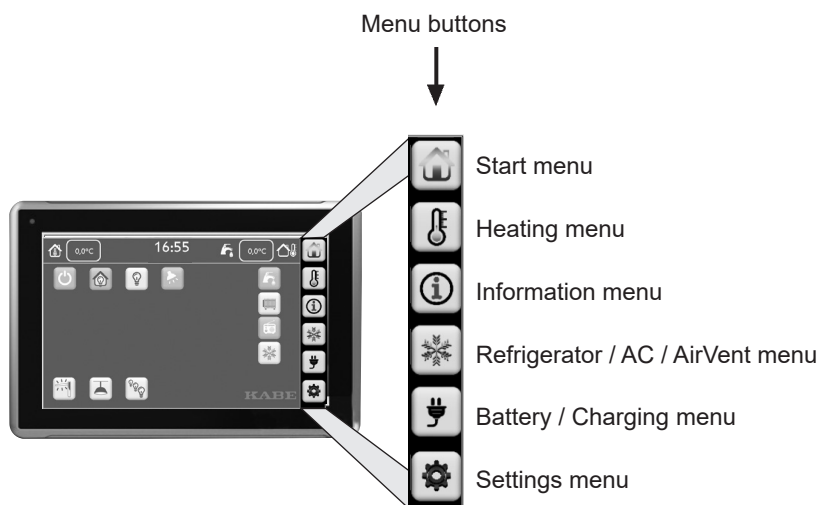

Electrical system off (Standby)

Even when the electrical system is off, some functions are available via the control panel.

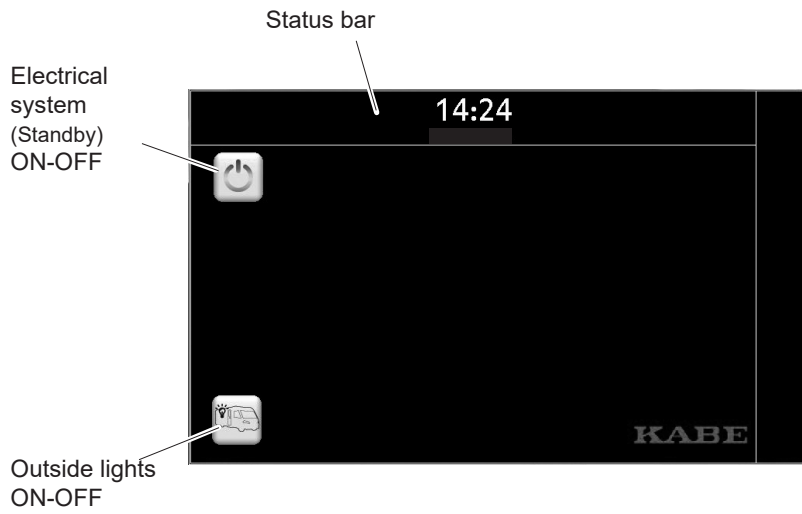

Descriptions

Start menu

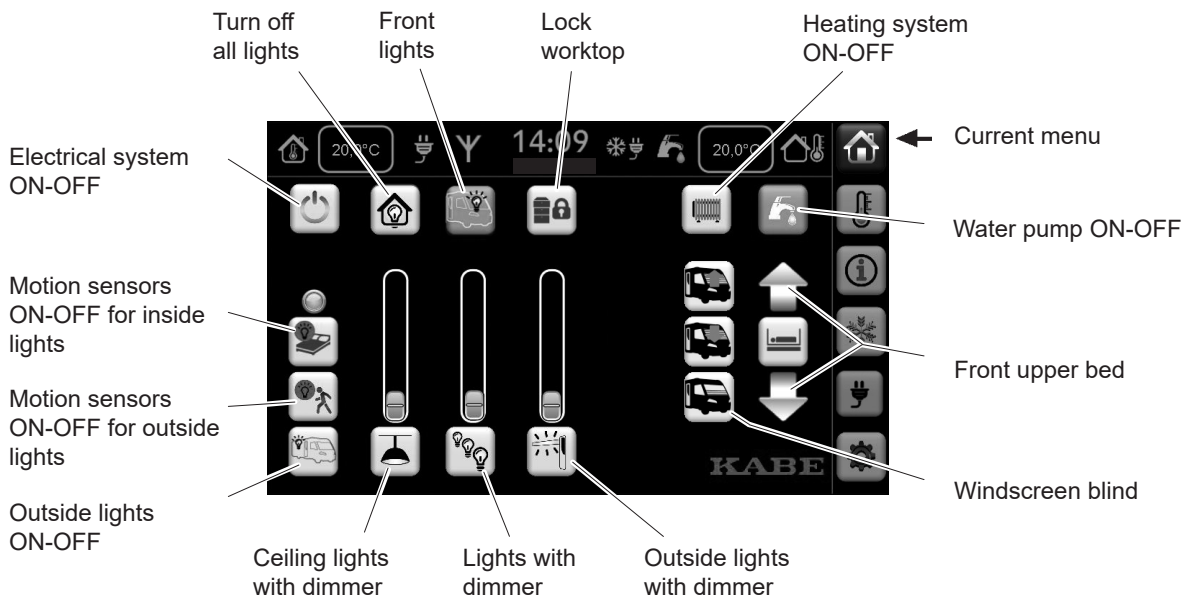

Heating menu

The boiler's control panel is in the wardrobe, but the most used functions are also available in this menu on the motorhome's control panel.

Heating system ON-OFF

Priority setting
• Electricity
• Gas

Winter connection
• Boiler
• Refrigerator

Night reduction of temperature (see Reference A below)

Desired temperature

Extra hot water

Immersion heater OFF-1-2-3 kW

Gas heating OFF-ON

Information on active functions

Fan speed adjustment

Temperature sensor selection:
• Lounge seating
• Bed
• Alde control panel
• Automatic selection

EisEX, 12 V defroster for gas regulator ON-OFF

Windscreen fan

Current menu

Floor heating

Reference A:

Night reduction of temperature

Activate night reduction until cancelled (no time limits)

Activate night reduction between stated times

Night reduction temperature

Start time / End time for night reduction

Information menu

Descriptions

Pump for draining the grey water tank ON-OFF

Shower fan ON-OFF

Drive mode (drains the tank until around 20 l remain)

Smart Level (Certain vehicles only.)
The coloured marking shows how the vehicle is leaning. Adjust the vehicle so that the marking is near the circle in the middle.

Shower basin's drain pump ON-OFF

Draining the fresh water tank

City water ON-OFF

Tyre pressure.
The battery icon shows when the sensor's battery needs changing.

Alarm when filling the fresh water tank

- 1 Before filling with fresh water, activate the alarm by pressing the icon.
- 2 The alarm goes off when the tank is full.
- 3 Switch off the alarm by pressing the icon (E) again.

Current menu

Level in the fresh water tank

Level in the black water tank (empty/full only)

Level in the grey water tank

Level in the gas bottle. (Certain vehicles only.)
Levels can be measured in metal gas bottles only.

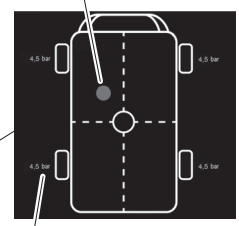
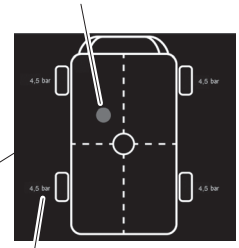

Tyre pressure.

The battery icon shows when the sensor's battery needs changing.

Current menu

Level in the gas bottle. (Certain vehicles only.)
Levels can be measured in metal gas bottles only.

Refrigerator / AC / AirVent menu

The refrigerator's functions can be adjusted from the control panel. See also the manufacturer's user instructions.

The AC menu is only available in motorhomes that have factory-fitted AC.

The AirVent menu is for the thermostat. The AirVent fan is started and adjusted via the fan's panel next to the roof hatch.

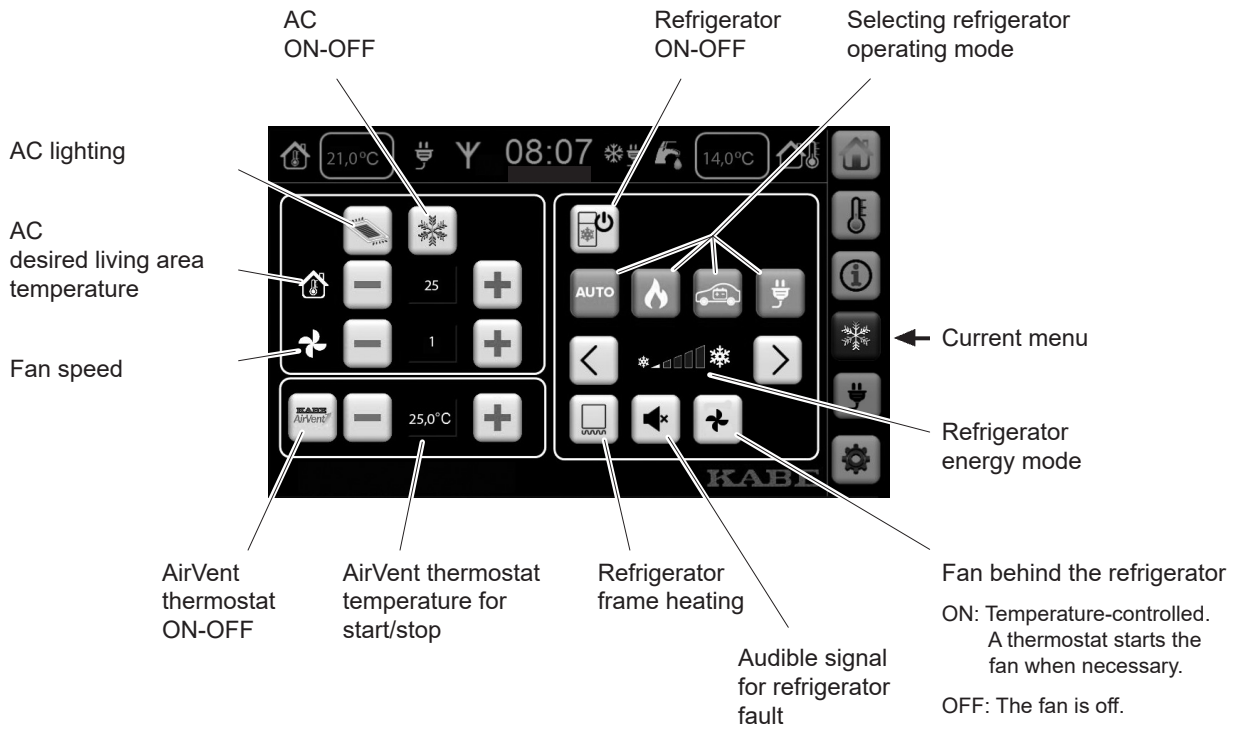

Descriptions

Batteries and battery charging menu

This menu shows battery charge levels.

The electrical system's power consumers are illustrated by a light in the menu.

Certain models have sensors that measure the current in the electrical system's various parts. Current consumption and charge are presented in the menu.

Motorhomes with a factory-fitted solar panel show present current from the solar panel.

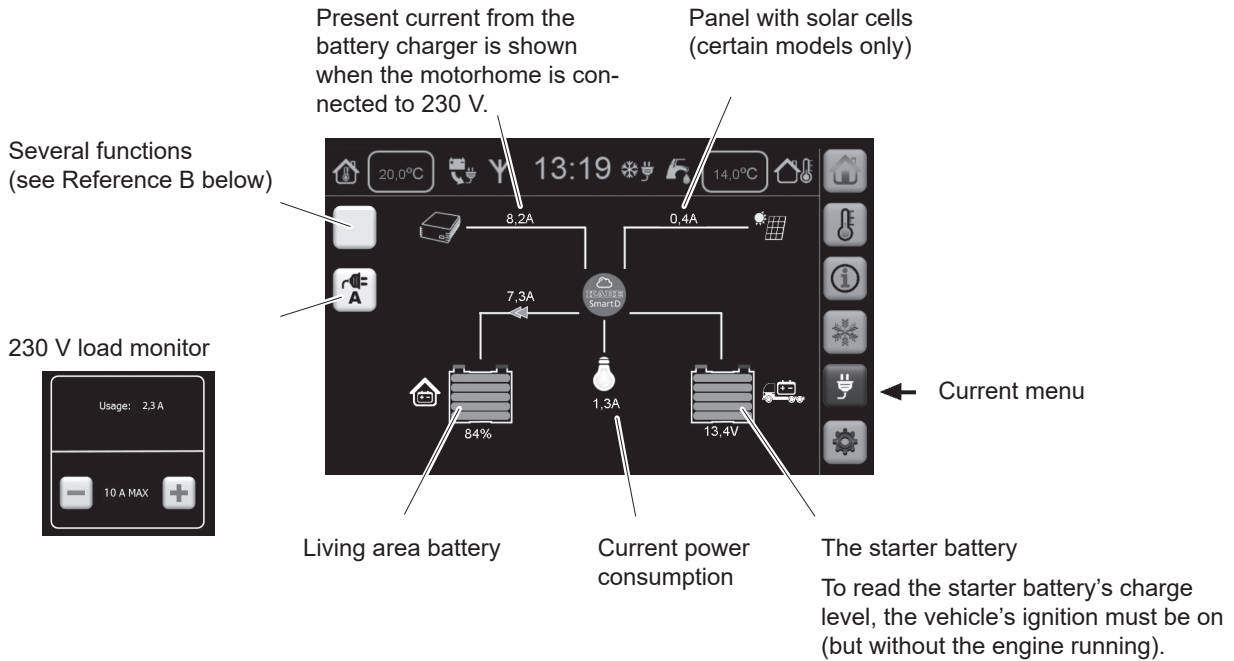

Reference B:

The button's function is affected by whether the motorhome is connected to a 230 V mains.

 Inverter, 12 V DC – 230 V AC, ON-OFF.
Shows only when the motorhome is not connected to 230 V.

 Silent mode with timer setting for the battery charger (reduced power).
Shows only when 230 V is connected.

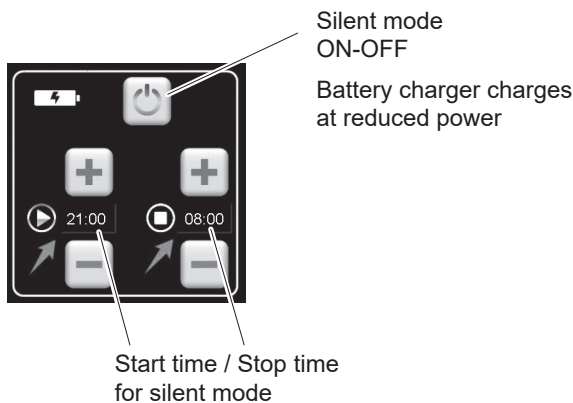

Settings menu

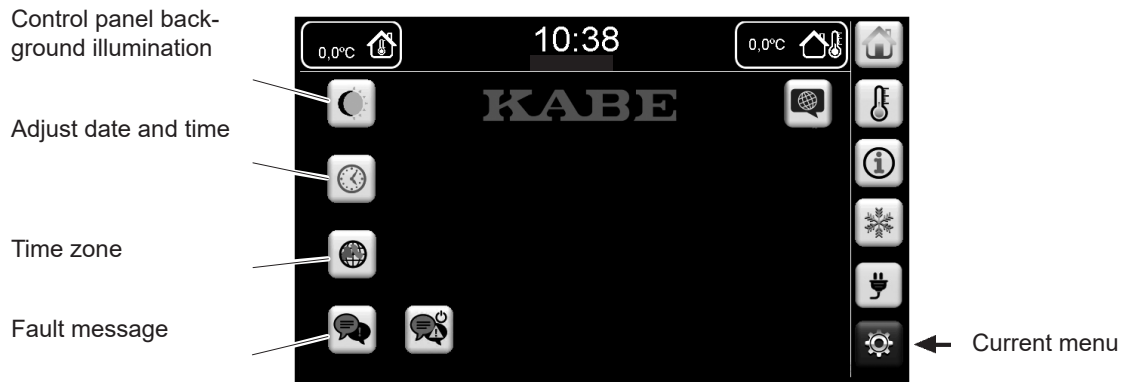

BATTERIES AND BATTERY CHARGING

The living area's battery.

The living area's 12 V system is powered by a battery located in a plastic box.

This battery is a so-called "leisure time" battery

The living area's battery is of the AGM type. Regular use is the best way of maintaining this battery's condition. The battery loses its charge when it is not used.

Any replacement battery must be of the AGM type. The motorhome's equipment is designed for this type of battery. Other battery types could damage the motorhome.

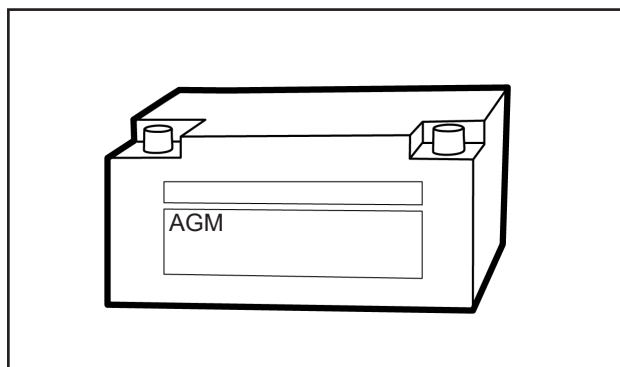

The living area's battery.

The vehicle's starter battery

The vehicle's 12 V system is powered by a starter battery in the floor next to the driver's seat.

The vehicle's 12 V system is used for the vehicle's traffic functions.

Certain models have a heated mat on the floor under the driver's seat. The starter battery is accessed by taking up the heated mat.

See the vehicle's user manual for details and descriptions of the vehicle's 12 V system.

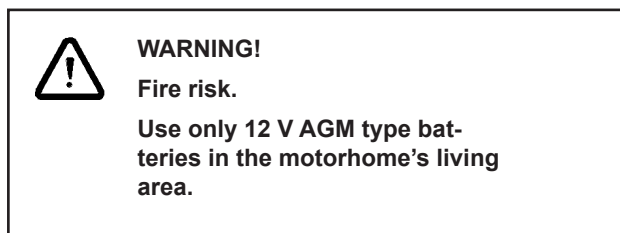

Charging during travel

Throughout travel, both the vehicle's starter battery and the living area's battery are being charged.

Using the 230 V AC battery charger

There is a battery charger installed in the motorhome.

The charger is permanently in circuit so that there is battery charging whenever 230 V AC is connected.

The battery charger "senses" battery charge requirements and adapts the charging current to this.

First, the living area's battery is charged. When the living area's battery is fully charged, starter battery charging begins.



The battery charger.

NB!

Do not cover the battery charger when it is connected. Risk of battery charger overheating.

Important!

See also the manufacturer's battery charger manual (supplied with the motorhome).

Vital information on the living area's battery

The battery's service life is affected by how it is used.

- Avoid heavily discharging the battery. Charge the battery before it is flat.
- Fully charge the battery (at least 24 hours). The battery charges ever more slowly as the charge grows.
- Charge the battery as soon as possible. The battery should never drop to half its charge. Fully charge the battery after use.

Check battery charge by reading battery voltage on the control panel.

For battery voltage level to equate to battery charge, the following must be taken into account:

- Battery load.
The battery's voltage level drops with load. Before reading battery voltage, switch off as many lights as possible and ensure that the refrigerator is not being powered by the 12 V system.
- Battery charging.
Ensure that the batteries are not being charged while reading voltage (i.e. engine turned off and 230 V not connected).

The following are guideline values at 20°C:

- > 12.5 V Battery fully charged.
- 12.2 V – 12.5 V Battery 50% charged.
- < 12.2 V The battery needs charging.

If the motorhome is not to be used for some time (e.g. throughout the winter), the battery must be stored in a dry and cool (i.e. frost-free) place.

A disconnected battery must be trickle charged every other month.

A connected battery must be charged every other week if the motorhome is not being used. Remember that a flat battery is more easily damaged by freezing than is a fully charged battery (see the table).

In cold weather, the battery is not able to supply as much current. However, its capacity is not lost; it returns with warmer weather (see illustration).

Batteries age; they charge less easily when old. They can work well, but do not have the same capacity as new batteries.

Keep the battery clean!

Ensure that there is good contact at the battery's connections. To remove any oxide, clean the terminals with a steel terminal brush. Protect the battery's terminals from oxide by coating them with terminal grease.



WARNING!

Battery fluid is corrosive.

Sluice all spills liberally with running water. If there is skin or eye contact, sluice liberally with water and contact a doctor.

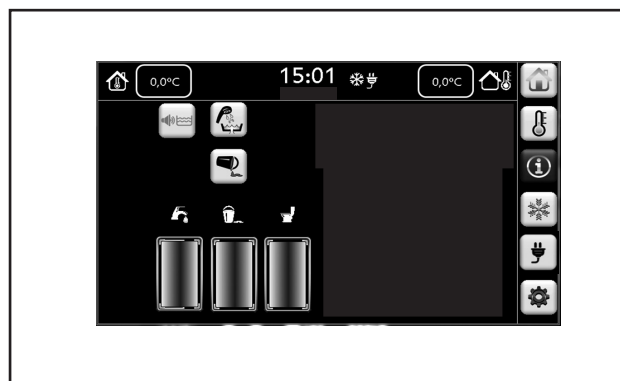

Density gr/cm ³	Freezing point °C
1.28 (full charge)	-67
1.24	-45
1.20	-27
1.16	-16
1.12	-10
1.10 (flat)	-7

The freezing point of the battery acid at different charge levels.

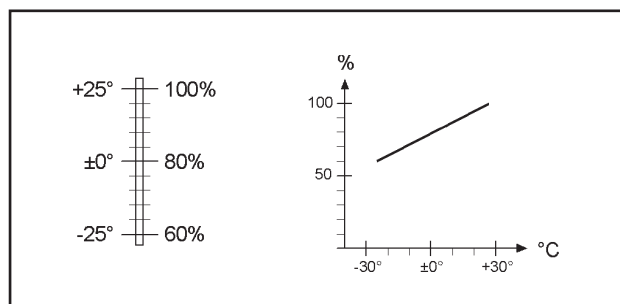

Battery capacity at different temperatures.

Automatic switch off at low battery level

The Smart D electrical system has in-built monitoring of battery charge.

When battery charge drops below a certain level, a message is shown on the control panel: “Low voltage AUX battery”.

Charge the battery (connect 230 V or start the engine).
To close the message, select a menu.

If battery charge drops even further, the electrical system automatically switches off large parts of the electrical system’s consumers. Electrical functions (e.g. lights and pumps) stop working. Because power to the electronics switches off, the refrigerator and boiler also switch off.

The purpose of switching off the electrical system is to avoid damaging the battery through discharging it too heavily.

The electrical system resets automatically when the battery is fully charged. Fully charging the battery takes a number of hours.

If you want to reset the electrical system earlier (at once), switch off the electrical system and turn the switch to the off position. If battery charging has started, this too must be interrupted so that the electrical system is not totally de-energised.

Next, start the electrical system while the battery is being charged.

The battery charger supplies enough power to reset the electrical system. All functions are available.

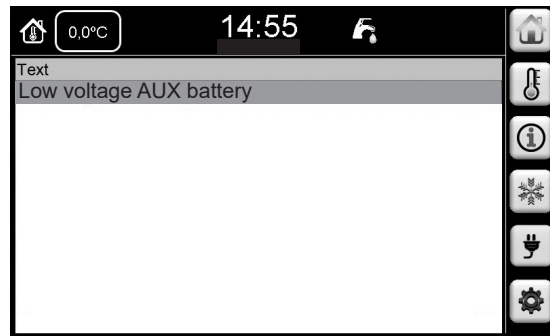

Silent mode

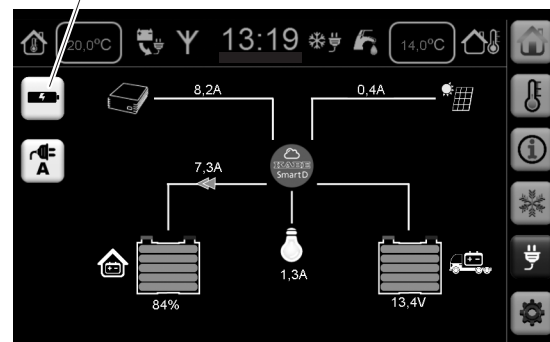

It is appropriate to use the battery charger at full power by switching off silent mode via the control panel.

LIGHTS

When changing a light bulb, the new bulb must be of the same type and strength as the original.

KABE predominantly uses LED bulbs. This reduces the power consumption of lights (i.e. the battery lasts longer compared to when using other bulbs). LED bulbs have a far longer life than traditional incandescent bulbs.

Some LED bulbs have the same base as traditional halogen bulbs. However, LED lights should still be chosen to limit power consumption and to avoid unwanted heat in the bulb.

LED bulbs of the same type can shine with different hues.

Incandescent bulbs and LED bulbs are regarded as perishable.



WARNING!

Risk of burns!

Lit halogen bulbs get hot. Fitting a halogen bulb instead of a low-energy bulb can cause overheating.

OUTSIDE LIGHT WITH MOTION SENSORS

Switch on the outside light via the control panel (A). The outside light is permanently on.

If the motorhome has motion sensors, icons (B) and (C) are shown on the control panel.

Activate the motion sensor by pressing the control panel (B). The outside light goes out after a few minutes. It comes back on if, in the dark, the motion sensor detects motion.

If button (C) is activated, some lights inside the vehicle follow the outside lights and are activated by the motion sensor.

The purpose is to make people inside the vehicle aware that the motion detector has detected motion outside the vehicle.

Switch the button (C) off if you would like the motion sensor to activate the outside lighting without disturbing inside the vehicle.

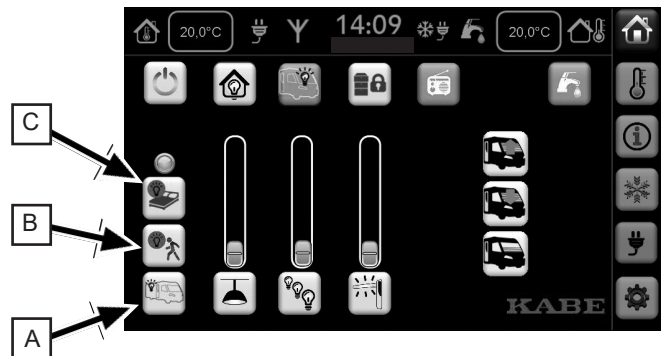

FUSES

230 V fuses

The motorhome's 230 V junction box has two circuit breakers.

- 16 A circuit breaker for the boiler's immersion heater.
- 10 A circuit breaker for battery charger, refrigerator and power outlets.

The electrical system has a residual current device for incoming power. Functionality can be tested using the recessed button on the circuit breaker's side.



Motorhomes with a factory-fitted inverter also have a residual current device mounted by the inverter. Its functionality can be tested via a button on the residual current device.



Smart D fuses

The electrical system's electrical outputs are continuously monitored. If an output is overloaded (too big a current), it is automatically switched off. This function equates to a fuse.

- 1 Ensure that the overloading is corrected.
- 2 Then switch off and restart the electrical system.

The Smart D electrical system comprises, amongst other things, units with electrical inputs and outputs. These units are marked N1 – N6 (N1 – N5 in certain models). An overview drawing shows unit location. This drawing is supplied with the motorhome.

Unit N1 has four 30 A fuses.

Each of the N2 – N6 units has a 20 A fuse.



The picture shows the electrical system's N1 unit.
Dometic Smart D 12 V Distribution Box.



The picture shows one of the electrical system's N2 – N6 units.
Dometic Smart D I/O card.

KABE Imperial / Crown (fully integrated motorhomes) fuses

As far as possible, the fuses are centrally located in junction boxes F1, F2, F3 and F4.
An overview drawing shows fuse location in the motorhome.

F1

F1-0	40A	Charging current between living area battery and starter battery
F1-37	10A	Central locking
F1-38	15A	Washer pump
F1-39	15A	DEFA alarm
F1-40	3A	Starter battery voltage measurement
F1-41	10A	Step (driver side)
F1-42	3A	DEFA IR
F1-43	7,5A	Side-view mirrors (heating)
F1-44	7,5A	Side-view mirrors (adjustment)
F1-45	7,5A	Fan (passenger seat)
F1-46	15A	Electric windows

Important!

Details of the fuses for the vehicle's 12 V system are given in the vehicle's user manual.

F1-0, 40A

F1-54	F1-53	F1-52	F1-51	F1-50	F1-49	F1-48	F1-47	F1-46, 15A	F1-45, 7,5A	F1-44, 7,5A	F1-43, 7,5A	F1-42, 3A	F1-41, 10A	F1-40, 3A	F1-39, 15A	F1-38, 15A	F1-37, 10A
-------	-------	-------	-------	-------	-------	-------	-------	------------	-------------	-------------	-------------	-----------	------------	-----------	------------	------------	------------

F2

F2-1	3A	Living area battery voltage measurement
F2-2	5A	ALDE boiler
F2-3	7,5A	Trickle charging of the living area battery
F2-4	15A	Step (the door)
F2-5	15A	Solar panel
F2-6	10A	Cinderella incinerating toilet
F2-	20A	Power amplifier / Subwoofer
F2-	20A	Power amplifier / Subwoofer
F2	200A	Inverter
F2	150A	Hydraulic support legs
F2	15A	Hand-held control (hydraulic support legs)

F2-3, 7,5A	F2-6, 10A
F2-2, 5A	F2-5, 15A
F2-1, 3A	F2-4, 15A

F2-7, 20A

F2, 150A

F2-8, 20A

F2, 150A

F2-9, 50A

F3

F3-1	3A	Control panel
F3-2	1A	Router

F3-2, 1A
F3-1, 3A

F4

F4-1	3A	IBS
F4-2	7,5A	Lithium battery, TBS (factory-fitted option)
F4-3	5A	Lithium battery, BMS (factory-fitted option)
F4-4	500A	Lithium battery (factory-fitted option)

*F4-4, 500A
*F4-2, 7,5A
*F4-3, 5A
F4-1, 1A

* LITIUM

Other fuses

The toilet's solenoid valve:
3 A fuse behind the flush button or in the toilet's back part.
See the toilet stool manufacturer's instructions.

Boiler:
2 A fuse on the boiler in a green fuse holder.

Fuse location

The illustrations below show the location of the F1, F2, F3 and F4 fuses.
Units N1 – N6 are also shown.

Please refer to the relevant model illustration.

Tm CrI 760 LGB

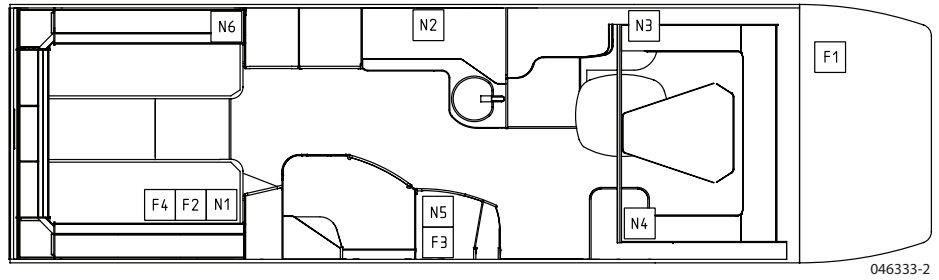

046333-2

Tm CrI 760 LXL
Tm CrI 810 LXL
Tm MI 810 LXL

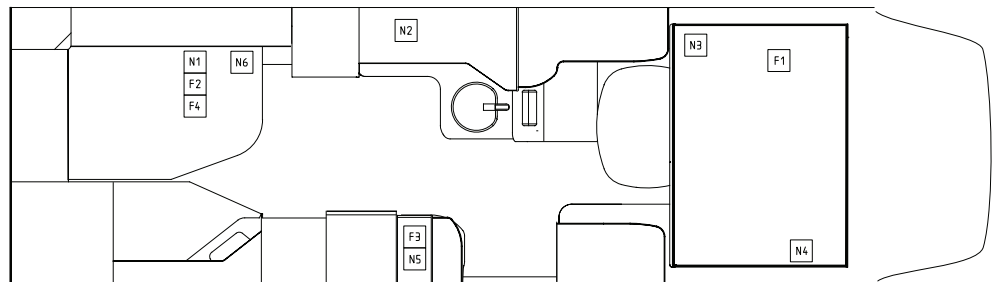

046292-1 / 046363-1

Tm CrI 810 LGB
Tm MI 810 LGB

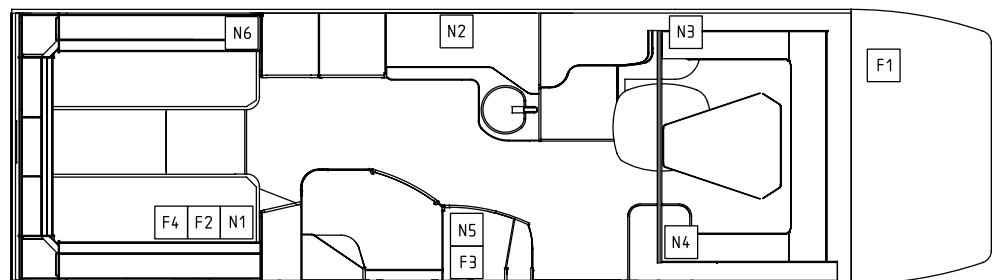

046325-2

Tm CrI 810 LQB
Tm MI 810 LQB

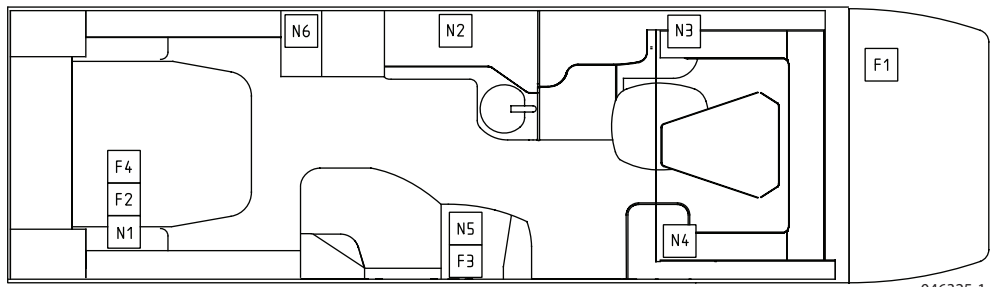

046325-1

Tm CrI 810 LT
Tm MI 810 LT

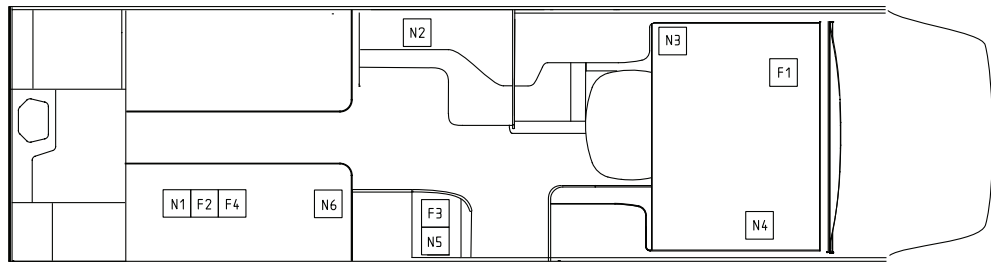

046261-4

Descriptions

Tm CrI 860 LQB
Tm MI 860 LQB

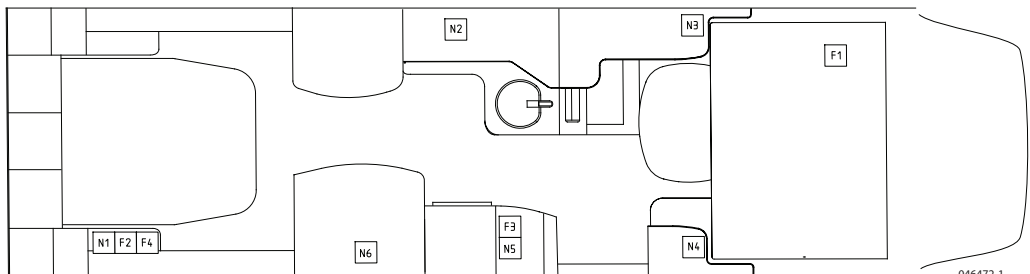

046472-1

Tm CrI 860 LGB
Tm MI 860 LGB

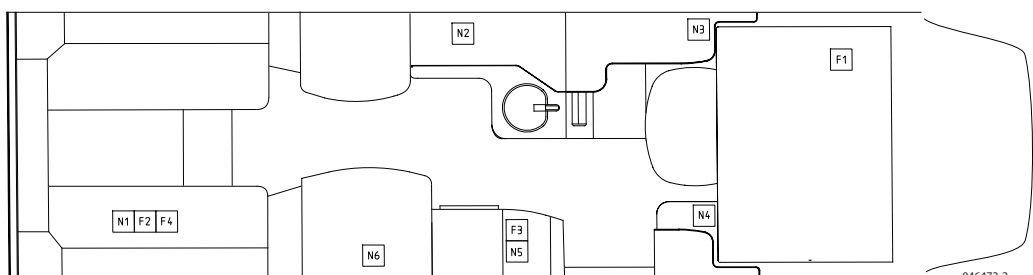

046472-2

Tm MI 910 GB

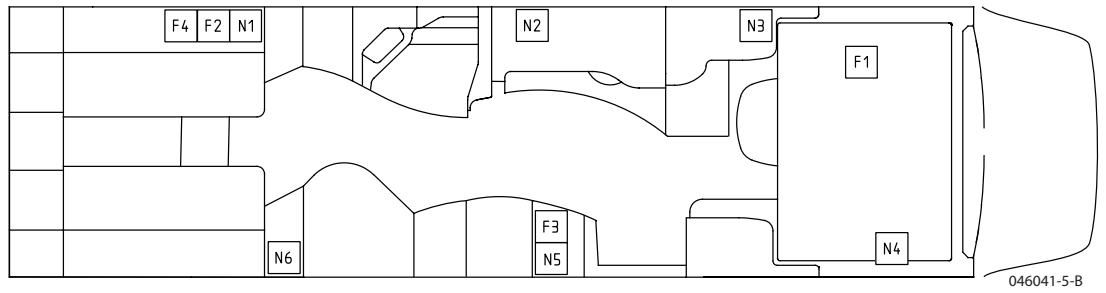

Tm MI 910 QB

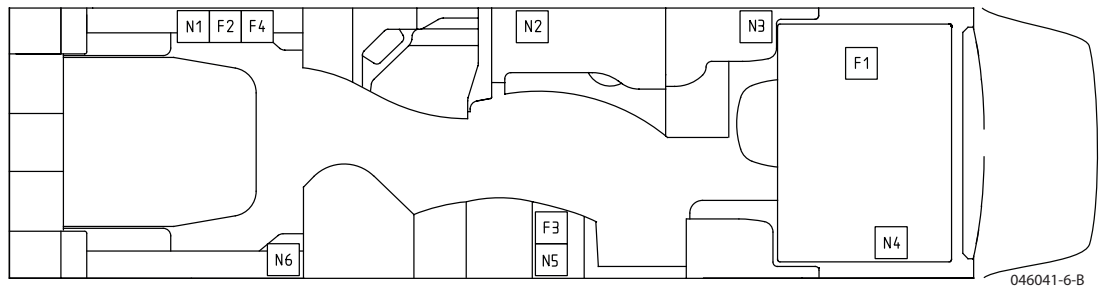

Tm MI 910 T

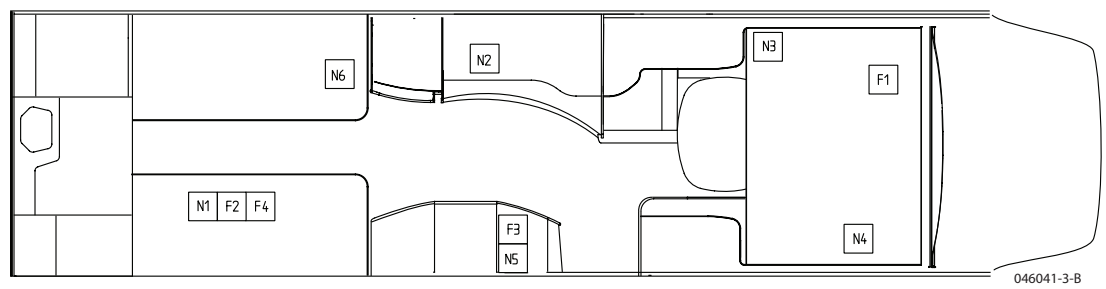

Descriptions

KABE Royal (semi-integrated motorhomes) fuses

As far as possible, the fuses are centrally located in junction boxes F1, F2, F3 and F4.
An overview drawing shows fuse location in the motorhome.

F1

F1-0	40A	Charging current between living area battery and starter battery
F1-37	3A	Starter battery voltage measurement
F1-38	15A	DEFA alarm
F1-39	- - -	
F1-40	3A	DEFA IR
F1-41	10A	Central locking

Important!

Details of the fuses for the vehicle's 12 V system are given in the vehicle's user manual.

F1-37, 3A	F1-38, 15A	F1-39	F1-40, 3A	F1-41, 10A	F1-42	F1-43	F1-44	F1-45	F1-46	F1-47	F1-48	F1-49	F1-50	F1-51	F1-52	F1-53	F1-54
-----------	------------	-------	-----------	------------	-------	-------	-------	-------	-------	-------	-------	-------	-------	-------	-------	-------	-------

F1-0, 40A

F2

F2-1	3A	Living area battery voltage measurement
F2-2	5A	ALDE boiler
F2-3	7,5A	Trickle charging of the living area battery
F2-4	15A	Bed TMX
F2-5	15A	Solar panel
F2-6	10A	Cinderella incinerating toilet
F2-7	50A	Charging current

F2-4, 15A	F2-5, 15A	F2-6, 10A
F2-1, 3A	F2-2, 5A	F2-3, 7,5A
F2-11, 50A		

F2	200A	Inverter
F2	150A	Hydraulic support legs
F2	15A	Hand-held control (hydraulic support legs)

F3

F3-1	3A	Control panel
F3-2	1A	Router

F3-2, 1A
F3-1, 3A

F4

F4-1	3A	IBS
F4-2	7,5A	Lithium battery, TBS (factory-fitted option)
F4-3	5A	Lithium battery, BMS (factory-fitted option)
F4-4	500A	Lithium battery (factory-fitted option)

* F4-4, 500A
* F4-2, 7,5A
* F4-3, 5A
F4-1, 1A

* LITIUM

Other fuses

The toilet's solenoid valve:
3 A fuse behind the flush button or in the toilet's back part.
See the toilet stool manufacturer's instructions.

Boiler:
2 A fuse on the boiler in a green fuse holder.

Fuse location

The illustrations below show the location of the F1, F2, F3 and F4 fuses.
Units N1 – N6 are also shown.

Please refer to the relevant model illustration.

Tm RX 780 LT

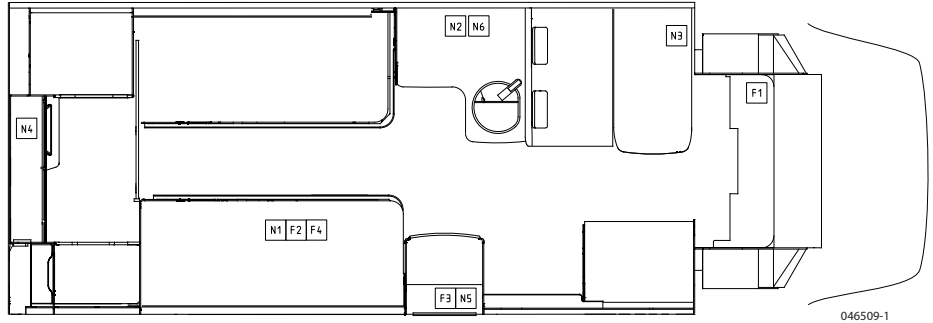

Tm RX 780 LB
Tm RX 780 LGB

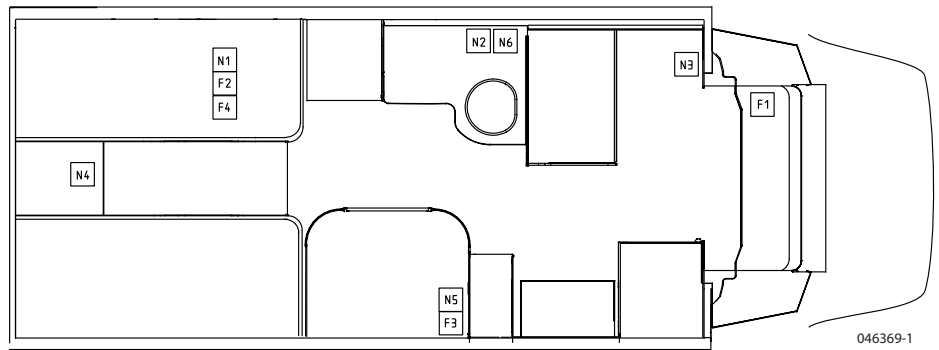

Tm RX 780 LXL

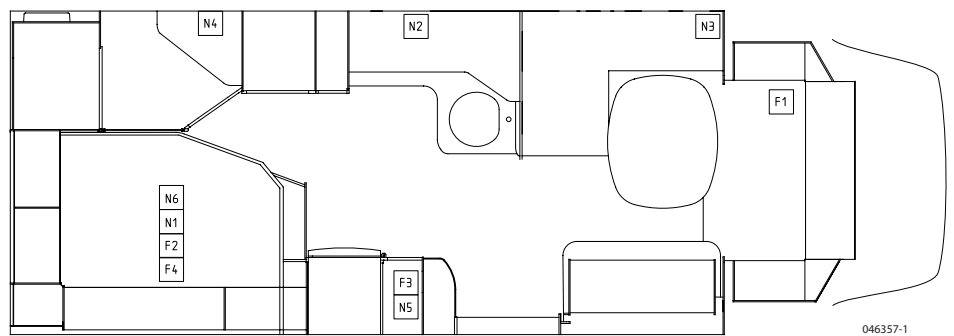

Tm RX 780 LQB

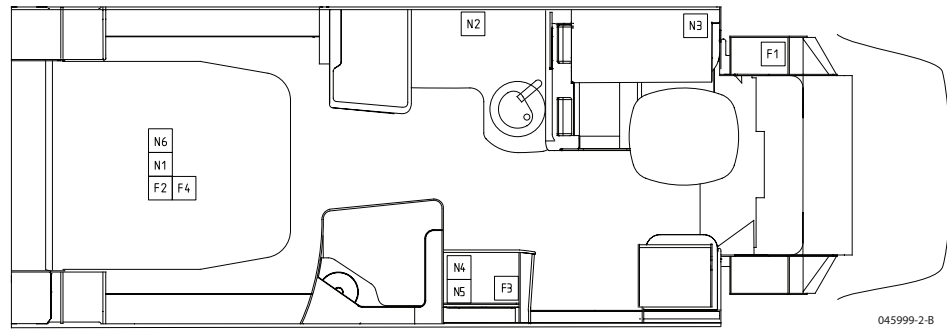

Tm RX 880 LQB

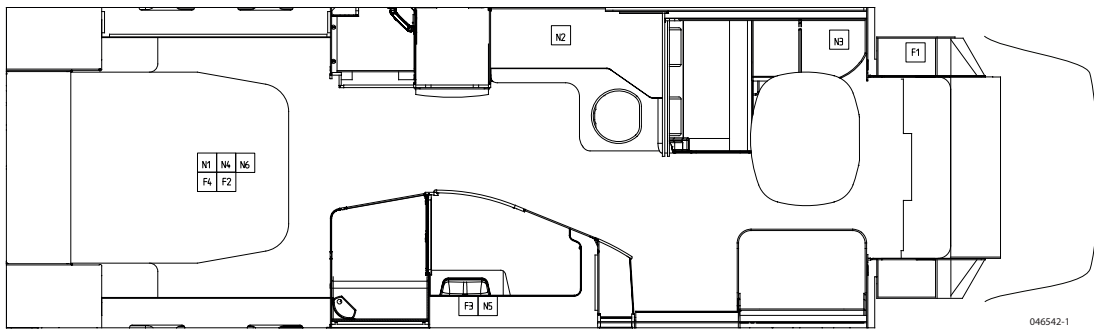

Tm RX 880 LT

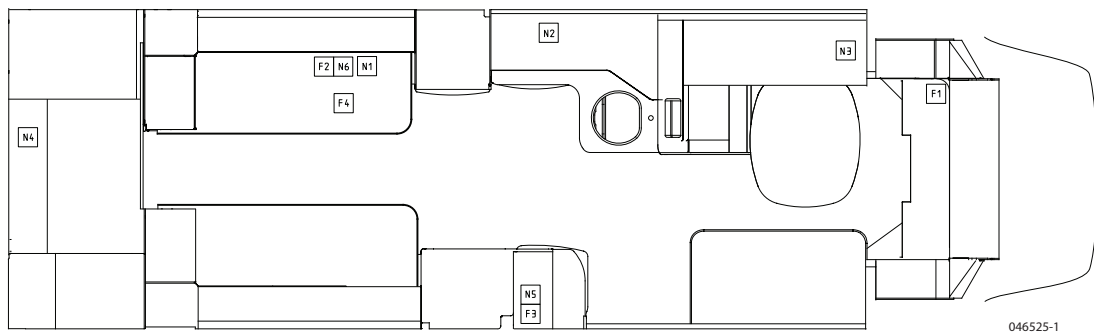

KABE Van fuses

As far as possible, the fuses are centrally located in junction boxes F1, F2 and F4.
An overview drawing shows fuse location in the motorhome.

Important!

Details of the fuses for the vehicle's 12 V system are given in the vehicle's user manual.

F1

F1-0 Charging current between living area battery and starter battery

F1-37 3A Starter battery voltage measurement
F1-38 15A DEFA Alarm (factory-fitted option)
F1-39 7,5A Signal voltage to isolation relay
F1-40 3A IR DEFA (factory-fitted option)

F1-37, 3A
F1-38, 15A
F1-39, 7,5A
F1-40, 3A

F1-0, 40A

F2

F2-1 7,5A Living area battery trickle charging
F2-2 3A Living area battery voltage measurement
F2-3 1A
F2-4 3A Smart D control panel
F2-5 5A ALDE boiler
F2-6 1A Router
F2-7 15A Step / Awning
F2-8 15A Solar panel

F2-9 150A Inverter

F2-3, 1A	F2-2, 3A	F2-1, 7,5A
F2-6, 1A	F2-5, 5A	F2-4, 3A
	F2-8, 15A	F2-7, 15A

F2-9, 50A

F4

F4-1 3A IBS
F4-2 7,5A Lithium battery, TBS (factory-fitted option)
F4-3 5A Lithium battery, BMS (factory-fitted option)
F4-4 500A Lithium battery (factory-fitted option)

*F4-4, 500A
*F4-2, 7,5A
*F4-3, 5A
F4-1, 1A

* LITIUM

Other fuses

The toilet's solenoid valve:
3 A fuse behind the flush button or in the toilet's back part.
See the toilet stool manufacturer's instructions.

Boiler:
2 A fuse on the boiler in a green fuse holder.

Fuse location

The illustrations below show the location of the F1, F2 and F4 fuses.
Units N1 – N6 are also shown.

KABE Van
Tm CrV 690 LB

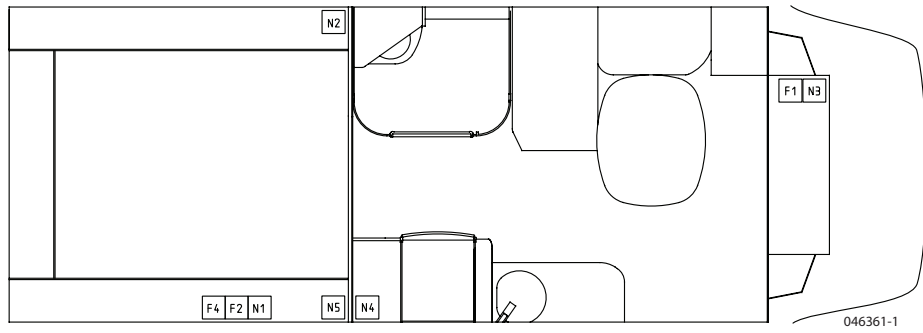

CIRCUIT DIAGRAMS

Smart D circuit diagram, KABE Imperial / Crown (fully integrated motorhomes) fuses

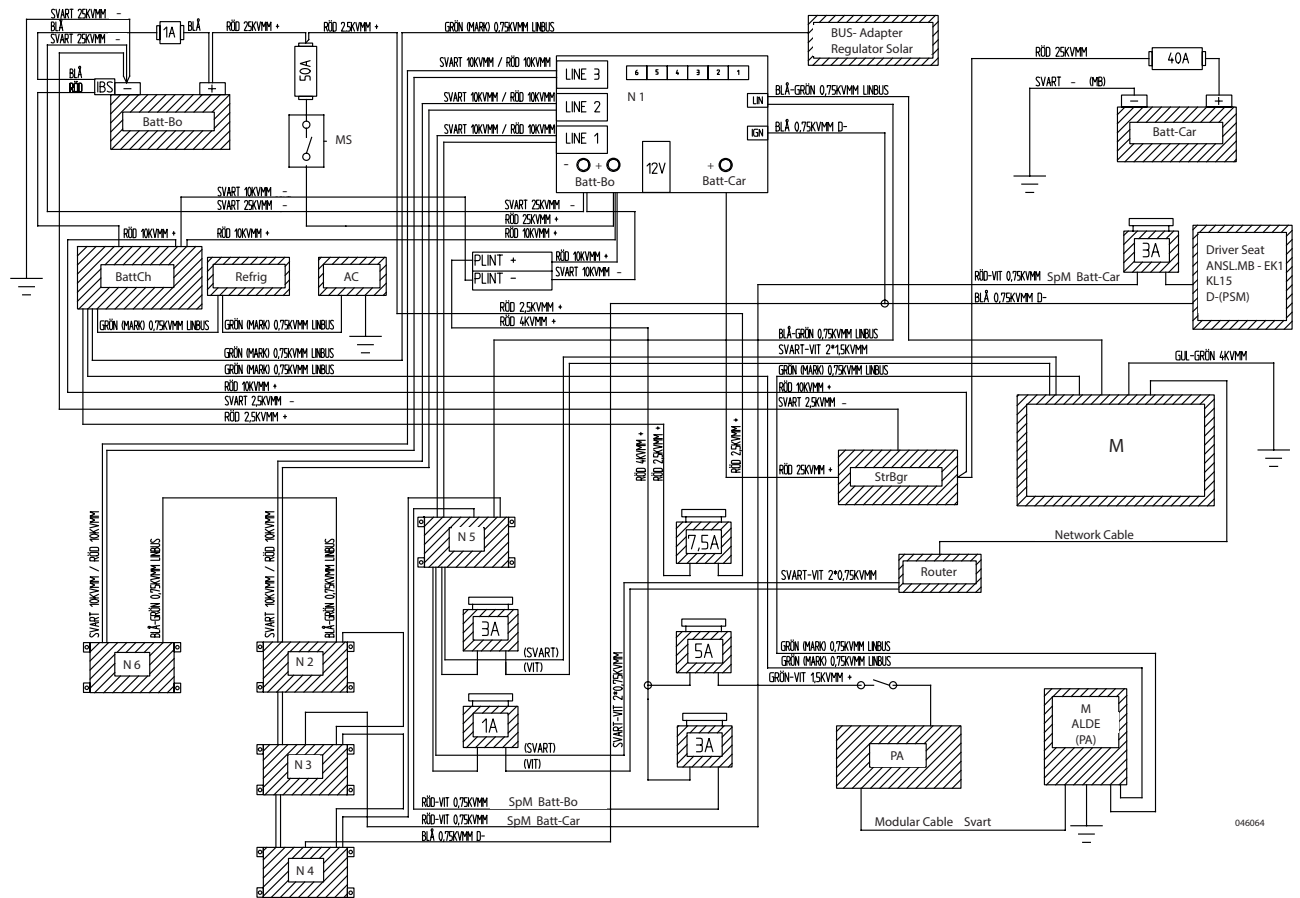

Key:

- 12V-Bo 12 V living area
- 12V-Car 12 V vehicle
- Batt Battery
- Batt-Bo Battery, living area's 12 V system
- Batt-Car Battery, vehicle's 12 V system
- BattCh Battery charger
- M Control panel
- MS Main power switch
- N1-N6 Electronic units with inputs and outputs
- PA Boiler
- PLINT Terminal block
- Refrig Refrigerator
- SpM Voltage meter
- StrBgr Current limitation

The order of unit (N) connection may vary between different models. There are no differences in functions.

Applies to:

- LIN-bus communication cable (blue-green).
- 12 V supply voltage (black-red).

Smart D circuit diagram, KABE Royal (semi-integrated motorhomes)

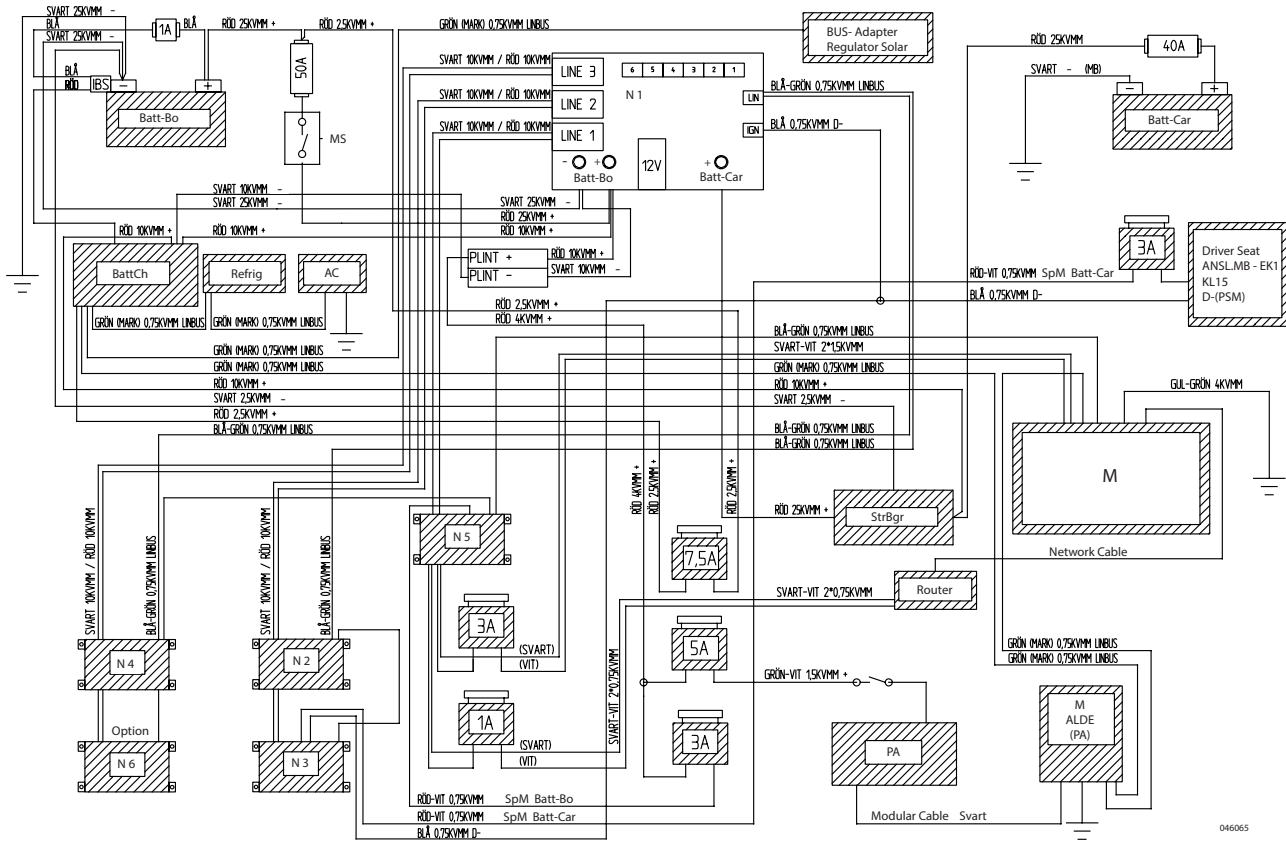

Descriptions

Key:

- 12V-Bo 12 V living area
- 12V-Car 12 V vehicle
- Batt Battery
- Batt-Bo Battery, living area's 12 V system
- Batt-Car Battery, vehicle's 12 V system
- BattCh Battery charger
- M Control panel
- MS Main power switch
- N1-N6 Electronic units with inputs and outputs
- PA Boiler
- PLINT Terminal block
- Refrig Refrigerator
- SpM Voltage meter
- StrBgr Current limitation

The order of unit (N) connection may vary between different models. There are no differences in functions.

Applies to:

- LIN-bus communication cable (blue-green).
- 12 V supply voltage (black-red).

Smart D circuit diagram, KABE Van

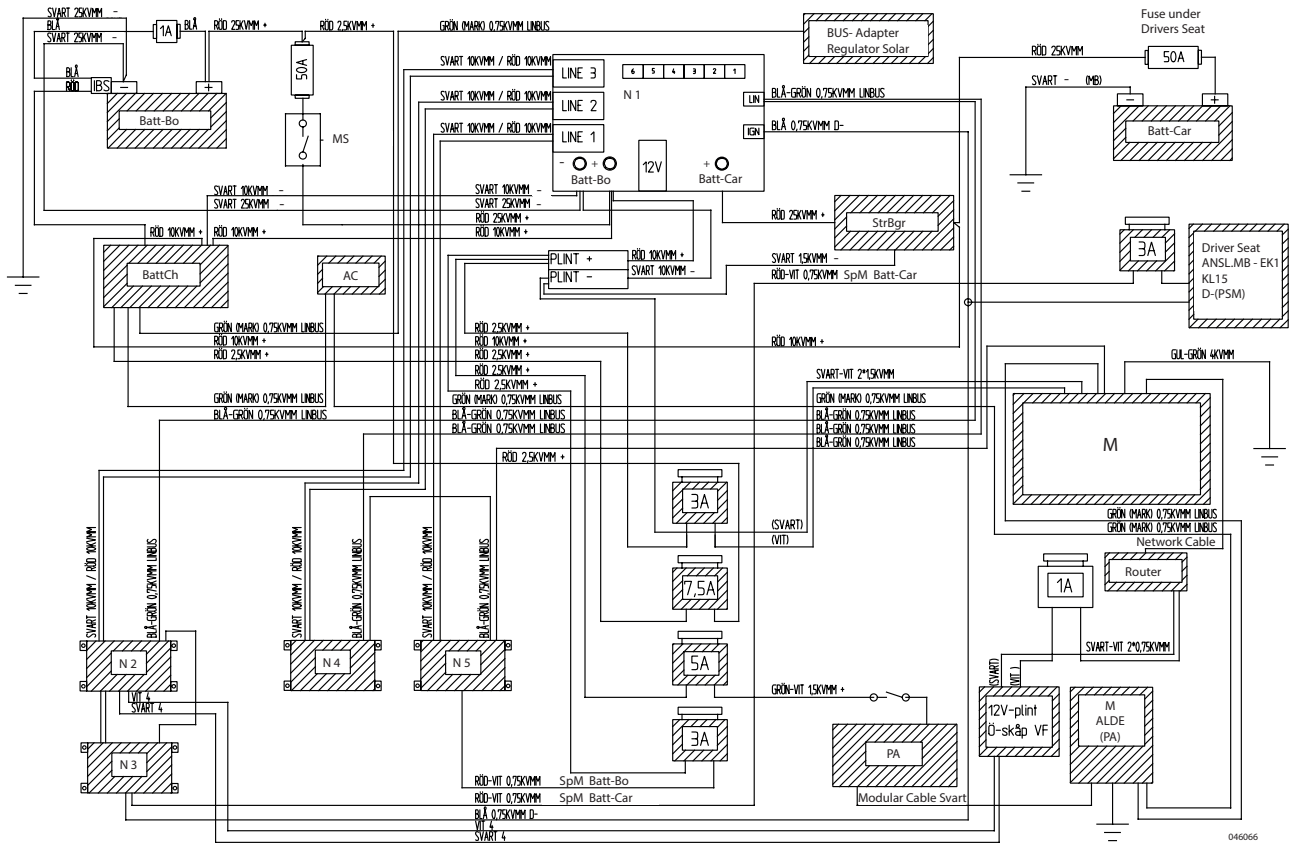

Key:

- 12V-Bo 12 V living area
- 12V-Car 12 V vehicle
- Batt Battery
- Batt-Bo Battery, living area's 12 V system
- Batt-Car Battery, vehicle's 12 V system
- BattCh Battery charger
- KVMM mm²
- M Control panel
- MS Main power switch
- N1-N5 Electronic units with inputs and outputs
- PA Boiler
- PLINT Terminal block
- Refrig Refrigerator
- SpM Voltage meter
- StrBgr Current limitation

PANELS WITH SOLAR CELLS

Certain motorhomes have solar cells in a panel on the roof. This panel comprises several interconnected solar cells.

When the sun shines on the panel's solar cells, electric current is generated. This charges the living area's battery

For the best possible charging capacity, the whole panel must be in sunshine.

If the panel is partly in shadow, current will be limited to the equivalent of the solar cell receiving least sunlight.

Remember that dirt and snow can limit the sunlight getting to the solar cells. Ensure that the panel is clean and free from snow.

The panel's electronics monitor the charging process so that the battery is not overcharged. The electronics are powered by current from the battery.

A switch turns off the panel's electronics and, thereby, also the solar cells. When the switch is in the OFF position, the battery cannot be charged by solar energy.

Turn off the panel's electronics when the solar cells cannot create any electricity. Turning off the electronics saves the battery's existing capacity. Turning off the panel's electronics is appropriate when, for example, the motorhome is parked in a garage.

So that the battery can be charged by solar energy, ensure that the panel's switch is in the ON position.

How much current the solar cells are producing can be read from the control panel.

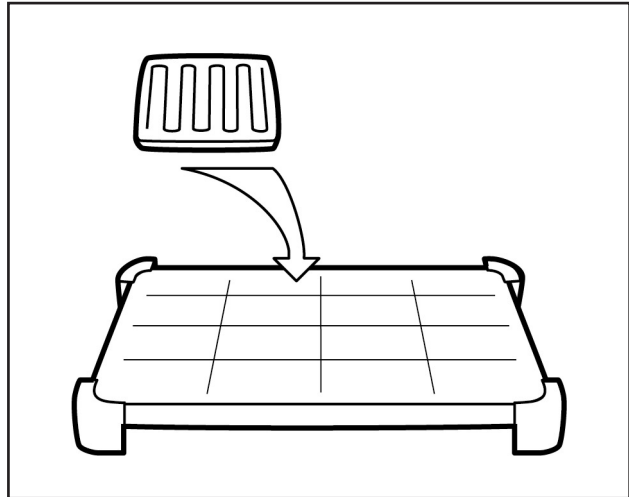

Panel with solar cells

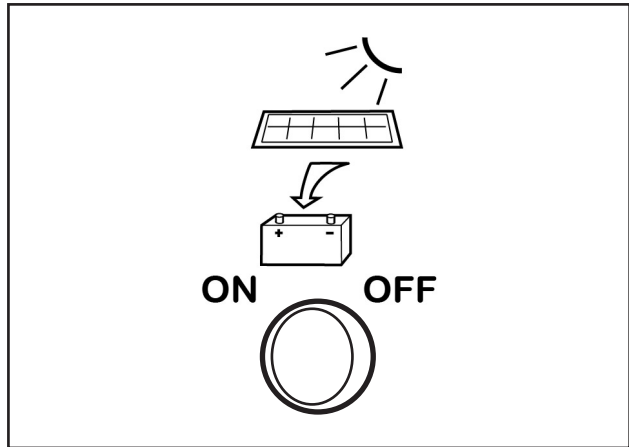

Solar cell switch ON-OFF.

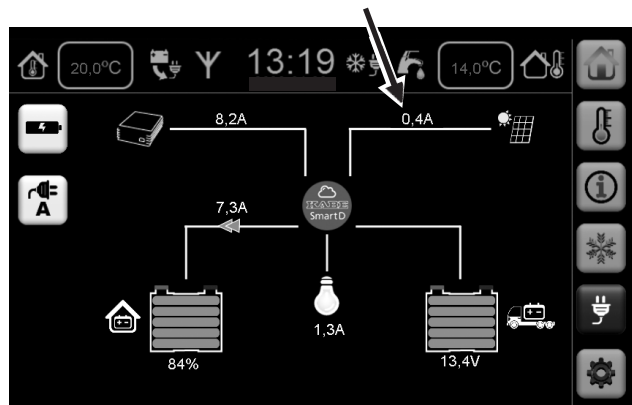

DESCRIPTIONS – ANTENNA SYSTEM

The motorhome has a TV antenna system.

The antenna system comprises:

- TV antenna,
- cable TV connection (K),
- signal switch,
- TV antenna socket,
- antenna mount.

To get the best possible reception, the antenna mount can be raised. (Certain models only.)

NB!
Throughout travel, the antenna must be in its bottom position and pointed backward.

Many camping sites now offer cable TV.

Cable TV is to be connected at the antenna socket (K).

When cable TV is connected to the motorhome, you must select whether the signal from the motorhome's antenna or from cable TV is connected to the antenna socket next to the TV shelf.

To select, press the appropriate button on the signal switch.

- A TV antenna,
- B cable TV.

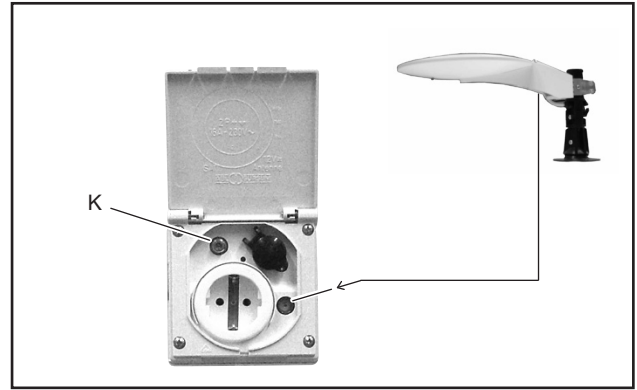

The motorhome's cable TV connection.

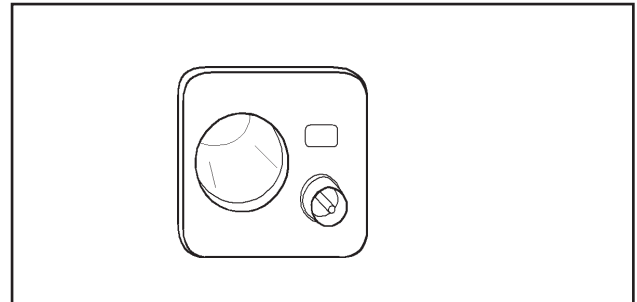

TV antenna socket.

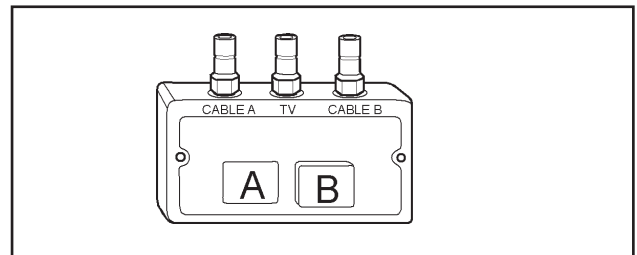

Signal switch.

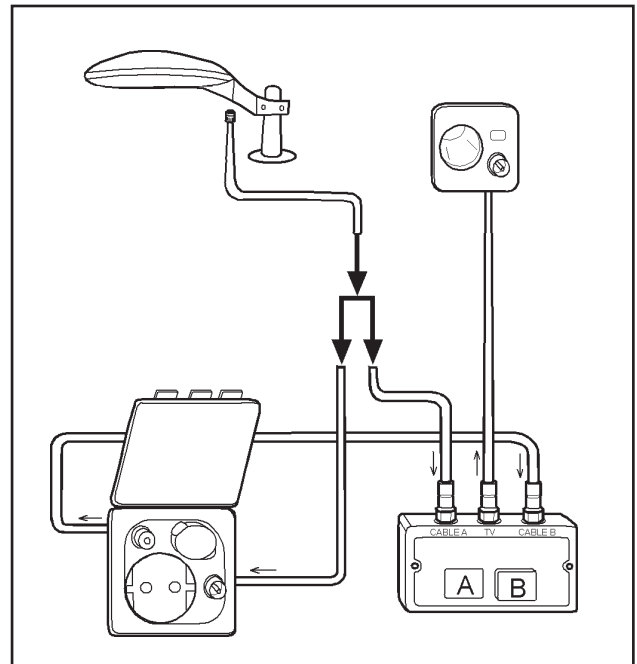

Schematic of the motorhome's antenna system.

KABE SMART D REMOTE

INTRODUCTION

KABE Smart D enables remote control of the vehicle's control panel from one or more mobile phones.

CONDITIONS

Remote control with KABE Smart D requires the vehicle to have the Smart D electrical system.

Certain models have Smart D Remote as standard. Other models with the Smart D electrical system can have Smart D Remote as an option.

The following conditions must be satisfied for remote control to work:

- Vehicle's electrical system on and internet connected. (Router and SIM card installed.)
- Mobile telephone has the Smart D Remote app installed and connected to the vehicle via a personal account.
- Mobile telephone is internet connected.
- Annual subscription is registered so that the function is active.

KABE distributors can help to get remote control up and running.



CONNECTING TO THE VEHICLE

When the vehicle's electrical system is internet connected, an activation code is displayed on the control panel (Settings menu).

The activation code must be registered with KABE.

The activation code is used to connect the vehicle to a personal email account (mobile telephone).

KABE recommends using a private email address. Email addresses of businesses or other organisations often have filters that can create problems for communication between vehicle and email account (mobile telephone).

CONNECTING SEVERAL MOBILE TELEPHONES

Several accounts (mobile telephones) can be connected to a single vehicle.

One account is the Owner account and authorised to approve other accounts that connect to the vehicle.

ON A CHANGE IN VEHICLE OWNERSHIP

Connect the new owner's account to the vehicle. Switch the Owner account to the new owner.

The account (mobile telephone) that is the Owner can disconnect other connected mobile telephones (accounts).

START MENU



Below, the start menu and the function of each icon are presented.

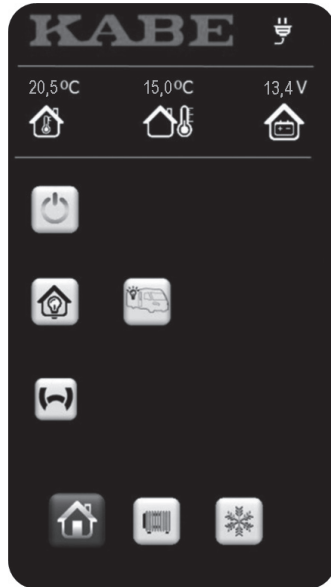

230 V connected



20,5°C
Inside temperature



25,0°C
Outside temperature



13,4 V
Current battery voltage
(living area battery)



Electrical system
ON-OFF



Turn off all lights



Webasto engine heater



Outside lights



Start menu
(Current menu)



Heating menu



AC / AirVent menu

HEATING MENU



230 V connected



20,5 °C
Inside temperature



25,0 °C
Outside temperature



13,4 V
Current battery voltage
(living area battery)



Heating
ON-OFF



Floor heating



Winter connection

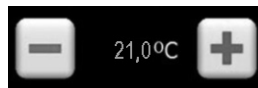

Desired temperature



Extra hot water



Immersion heater
OFF-1-2-3 kW



Gas heating
OFF-ON



Start menu



Heating menu
(Current menu)



AC / AirVent menu

AC / AIRVENT MENU



Certain models have both AC and AirVent. Other models display the functions available in the vehicle.

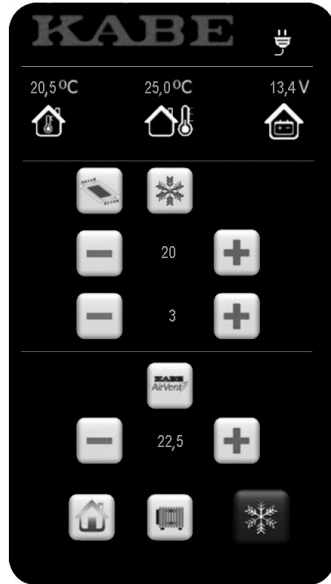

230 V connected



Inside temperature



Outside temperature



Current battery voltage
(living area battery)



AC lighting



AC: ON-OFF



AC: Desired living area temperature



AC: Fan speed



AirVent thermostat: ON-OFF



AirVent thermostat:
Temperature for start/stop



Start menu



Heating menu



AC / AirVent menu
(Current menu)

MAINTENANCE

MAINTENANCE SCHEDULES

This section contains only lists and timings of the maintenance that has to be carried out periodically. In certain cases, the maintenance measures are complemented with comments or references to more detailed instructions.

WEEKLY MAINTENANCE

Measure	Comment/Reference
Cleaning the fresh water tank.	See "Use".
Cleaning the grey water tank.	See "Use".
Using the leak indicator to check the bottled gas system.	See "Use".
Fluid level in the heating system.	Check the level in the expansion tank.

MONTHLY MAINTENANCE

Measure	Comment/Reference
Battery.	Fully charge the battery at least once a month.
Lubricating the toilet's rubber gaskets.	See "Descriptions" and the manufacturer's user instructions.
Cleaning the rubber gaskets/washers of the toilet's flush hatch.	See "Descriptions" and the manufacturer's user instructions.
Cleaning the kitchen fan's filter.	See "Descriptions" and the manufacturer's user instructions.
Draining the water heater (boiler)	To create a new air cushion in the water heater.
Leather covered cushions.	Treat as per the manufacturer's instructions.
Outside panels.	Ensure that fibreglass surfaces are protected against discolouration by waxing them at least twice a year.

YEARLY MAINTENANCE

Measure	Comment/Reference
Yearly service.	As per the guarantee and service book. Use a KABE service workshop.
Heating system fluid.	Check the glycol level using a glycol tester (refractometer). See "Descriptions".
Locks.	Lubrication.
Step articulations.	Lubrication.
Step switches.	Cleaning. Use contact spray.
Support legs.	Lubrication.
Rubber strips on doors and hatches.	Lubrication.
Bleeding the convectors.	See the separate maintenance instructions.
Cleaning the back of the refrigerator.	Remove any dust insulating the cooling fins. See the manufacturer's user instructions.

Spares: Ensure that you have extra bulbs and fuses.

CLEANING

WASHING THE EXTERIOR

General

Pay attention to the following when washing the exterior of the motorhome:

- Use only recommended cleaning agents.
- Follow the instructions on each cleaning agent's packaging.
- Incorrect cleaning can damage the motorhome's finish or trim.
- Respect any instructions in the vehicle's user manual.

Automatic car washes

KABE recommends that its motorhomes should not be washed in automatic car washes.

Hand washing is recommended. It is far gentler on the motorhome than is an automatic car wash.

High-pressure washing

As powerful jets of water can damage trim, avoid high-pressure washing.

Washing by hand

- 1 Sluice down the motorhome liberally with water. Avoid spraying the motorhome's ventilation openings.
- 2 Wash the motorhome with lukewarm water and a mild car shampoo. Use a sponge or washing brush.
Avoid washing the motorhome in direct sunlight. Rinse the cleaning agent off the motorhome within 10 minutes.
Windows must be cleaned separately using a cleaning agent for acrylic windows.
See the "Cleaning of windows" heading.
- 3 Use a hard wax polish to remove any asphalt splashes, soot particles and other dirt. Work the surface with a soft sponge or rag until the dirt comes off.
- 4 To protect your motorhome's finish after washing, treat it with wax.



WARNING!

Risk of injury.

**Take great care when cleaning the roof.
Remember the risks of slipping and falling.
Ensure that you are on a stable surface.**



Cleaning agents and degreasing agents

To avoid damaging sealants in the motorhome's joints and around its fittings, use only cleaning agents intended for motorhomes or caravans.

Suitable cleaning agents can be obtained from your local KABE distributor. Be careful with the strength of cleaning agent solutions. Avoid using too much cleaning agent.

Do not use degreasing agents.

Use a hard wax polish to remove tar and asphalt splashes.

Cleaning of windows

The motorhome's windows would be damaged by unsuitable cleaning agents.

Dometic Glass Cleaner is recommended for window cleaning.

Scratches on windows can be polished with Dometic Acrylic Glass Polish and a Dometic Special Polishing Cloth.

The above aids are included in the Dometic Window Cleaner Set.

Discolouration

Externally, the motorhome's panels and roof are made of aluminium, fibreglass and plastic. The colours of these materials are affected by solar radiation and other environmental factors. The materials may be subject to discolouration.

Prevent discolouration by regularly treating with wax.

If discolouration arises, it should be immediately remedied as follows:

- Polish out the discolouration. More advanced discolouration requires initial "rubbing". Severe discolouration may even require wet sanding before rubbing and polishing.
- Use polish to restore the shiny finish.
- Seal the finish with a suitable sealer.
- Prevent new discolouration by treating with wax.

Take care not to damage any trim during these treatments.

Special cleaning

This relates to semi-integrated motorhomes with a ceiling bed.
Ensure that drain holes are open so that water can run out.

Certain plastic details on the motorhome's roof have drain holes. If the drain holes get clogged with dirt, there is a risk of moisture collecting under the plastic details. This can cause damage.
Regularly check that the drain holes are open.

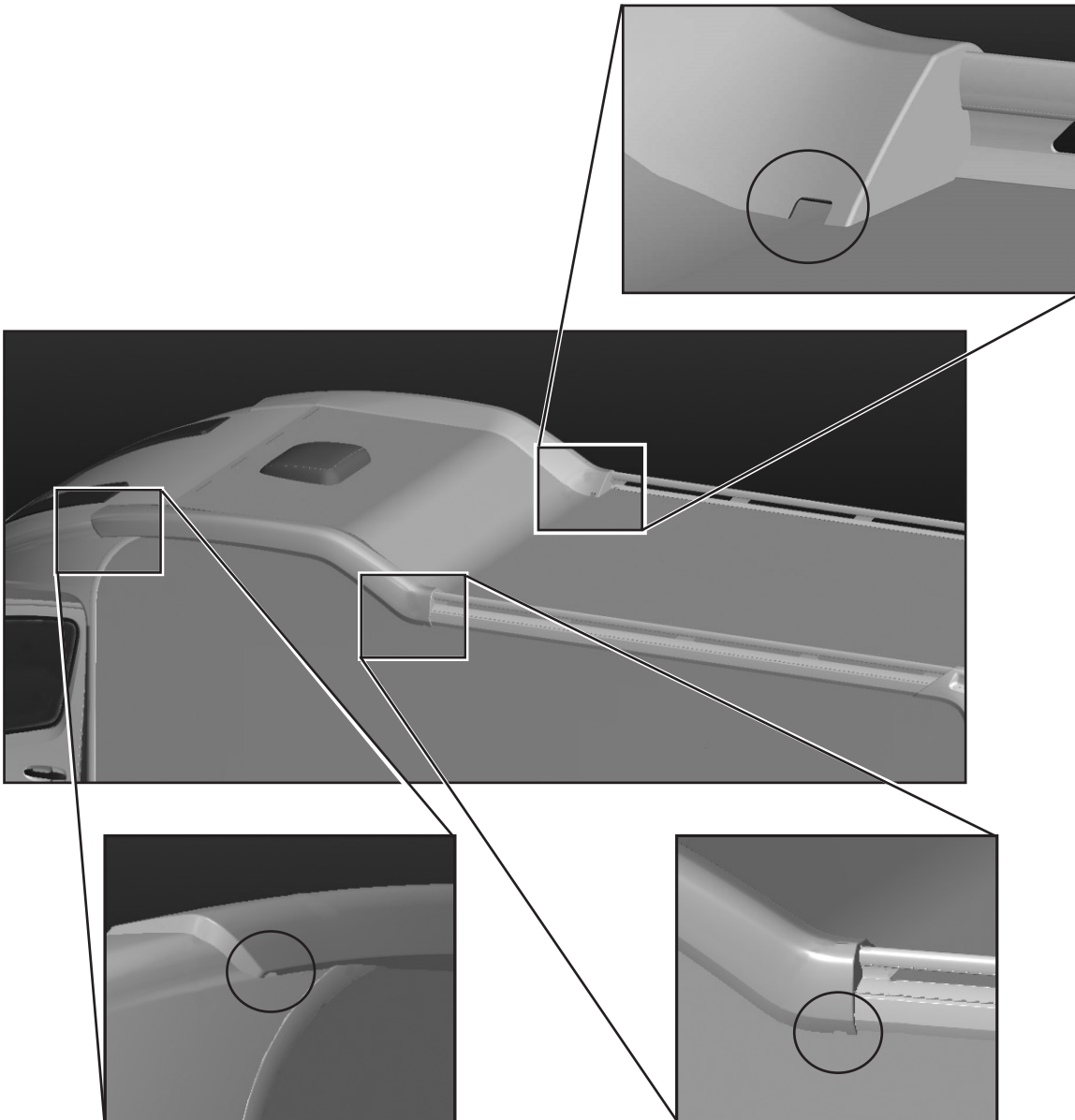

CLEANING THE INTERIOR

Textiles

Use a vacuum cleaner and brush to clean the cushions. Stains must be removed before they dry in. See the manufacturer's instructions.

Cushion textiles are removable and can be dry-cleaned if necessary.

Leather covered cushions are to be treated as per the manufacturer's instructions.

If necessary, bedspreads, curtains and curtain ties can be dry-cleaned.

Floor coverings are to be washed by moistening (not soaking) them with water and a mild detergent for textiles.

Ceiling and wall coverings

The living area's interior walls have a synthetic wall covering. This can be vacuumed. Stains can be removed with soap and water.

Use a slightly damp rag (dipped in a mild soap solution) to clean the ceiling. Wipe it over with a rag dipped in water alone.

Interior fittings

The wood and veneer surfaces of interior fittings can be wiped over with a rag. Use a slightly damp rag to remove stains.

Do not use solvents or similar. These may dissolve coatings and veneers.

Toilets

Clean the toilet as per the manufacturer's instructions. Ensure that you use only recommended cleaning agents. See the manufacturer's instructions.

CUTTING BOARDS

The cutting board is wood with an untreated surface. To increase the cutting board's resistance to discolouration or other effects of foodstuffs, the surface can be treated with an agent intended for kitchen worktops. This may be, for example, a hard wax oil.

LONG-TERM STORAGE

Long-term storage here refers to extended storage during which the motorhome is not used (e.g. over the winter).

PRECAUTIONS BEFORE LONG-TERM STORAGE

- Fill with fuel. This avoids condensation forming in the tank.
- Increase tyre pressure.
- Clean the motorhome.
Wash and wax the bodywork.
Clean the underside of the motorhome.
Clean the interior.
- Lubricate locks, hinges and door/hatch strips.
- Ensure that the fluid in the heating system has sufficient frost protection (glycol).
- Remove cushions and textiles.
Store them in a dry place indoors.
- Drain and clean the fresh water system.
For instructions, see “Use”.
Leave the fresh water tank’s drain cock in the open position.
- Drain the water heater.
Leave the drain valve in the open position.
- Ensure that all water taps are in the open position for both hot and cold water.
- If a water purifier (option) has been fitted, remove it.
See separate instructions.
- Drain and clean the grey water system. For instructions, see “Use”.
Leave the grey water tank open by not putting the plug back in the flushing outlet. This avoids condensation in the grey water tank.
- Ensure that the shower drain is empty and, where necessary, protected against frost.
- Clean the toilet, its connections and waste tank.
See the manufacturer’s instructions for storage and avoiding damage caused by freezing.
- Remove the starter battery and the living area’s battery.
Charge the batteries.
Store the batteries in a frost-free and dry place.
Trickle charge the batteries every third month.
See the “Descriptions – Electrical system” section.
- Empty the refrigerator.
Leave the refrigerator (and, where applicable, freezer compartment) door slightly open.
- Leave cupboards, wardrobes, drawers and sofa lids slightly open so that all areas in the motorhome are ventilated.
- Fit the winter hatch to the refrigerator’s ventilation grille.
- Close the gas bottle’s master valve and all gas supply valves.

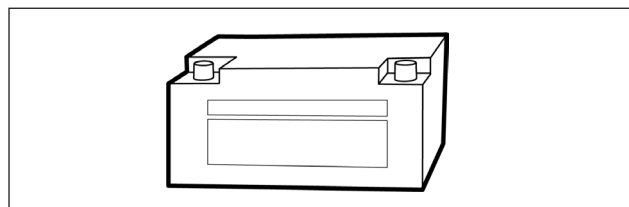
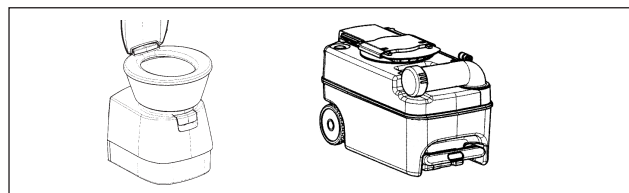
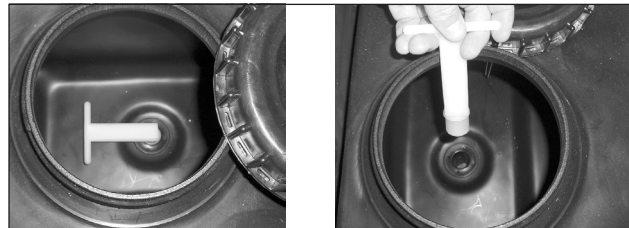
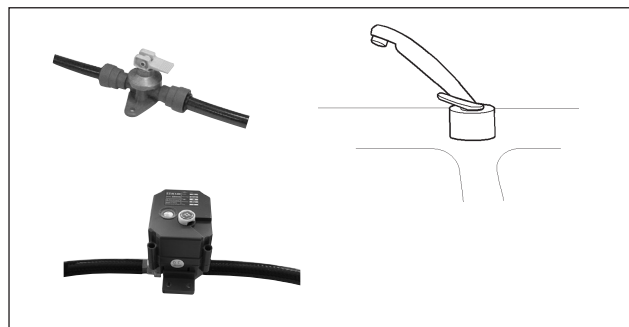
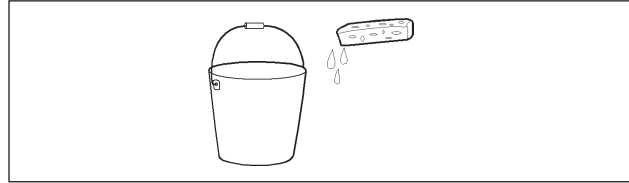

Recommended

- Place a dehumidifier (desiccant) in the motorhome.
- Ease the load on the wheels. To avoid tyre deformation, increase tyre pressure.

PRECAUTIONS DURING LONG-TERM STORAGE

- Trickle charge the batteries every third month.
See the “Descriptions – Electrical system” section.

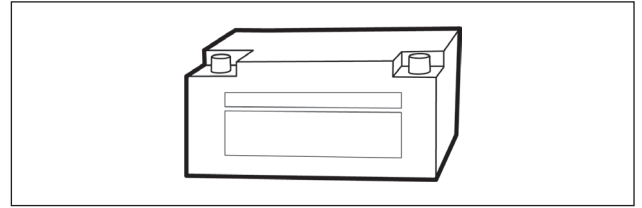

- Air the motorhome once a month.
- Check the liquid level in the dehumidifier.
- Check that the motorhome’s ventilation is not obstructed.

PRECAUTIONS BEFORE USING AFTER LONG-TERM STORAGE

- Charge the batteries.
- Fit the motorhome’s batteries.
Check that no circuit breakers have tripped.

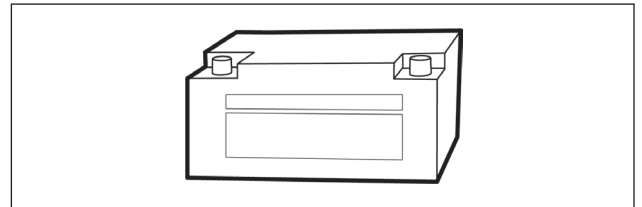

- Use the leak indicator to check the bottled gas system.

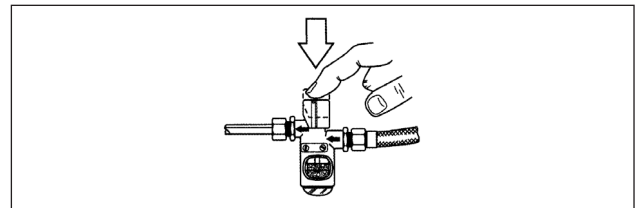

- Fit the rubber plug in the grey water tank’s flushing outlet.

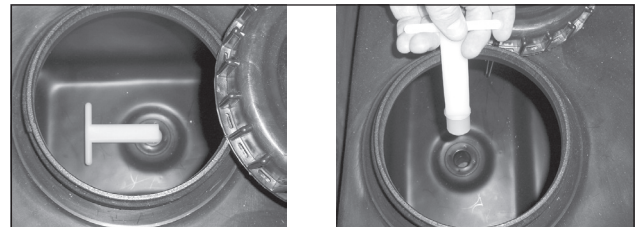

- Fit the cap to the toilet’s waste tank.
Ensure that the toilet’s waste tank is correctly positioned.
- Ensure the toilet is ready for use.
(All/any draining/emptying devices are closed.)

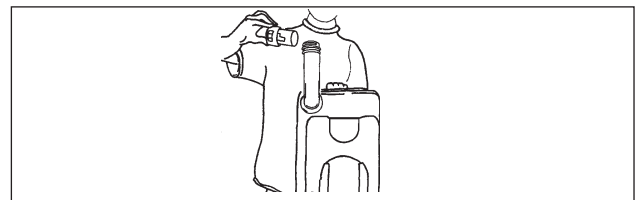

- Close the fresh water tank’s drain cock.
Open the drain cocks for the cold and hot water hoses.
- Close the water heater’s drain valve.

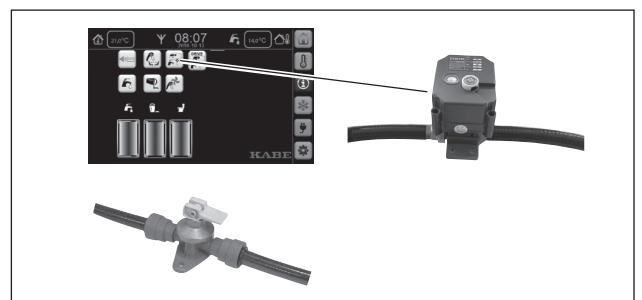

- Lubricate the support legs.
- Check tyre pressures (spare wheel too).

BLEEDING THE CONVECTOR SYSTEM

Air in the convector system impedes fluid circulation, i.e. warmth is unable to spread throughout the motorhome. Thus, the convector system must be bled via the bleed nipples.

Bleed as follows:

- 1 Ensure that the expansion tank contains a sufficient quantity of a glycol solution.
- 2 At the motorhome's control panel, switch off the circulation pump.
- 3 Park the motorhome facing slightly uphill.
Air bubbles will then collect at the front of the convector system.
- 4 Protect interior fittings near the bleed nipples by keeping a rag or paper by each nipple.
- 5 Open the nipple and vent all the air.
Close the nipple when only fluid starts to come out.
- 6 Bleed all nipples.
- 7 Move the vehicle so that it is facing slightly downhill.
Repeat bleeding.
- 8 It may be necessary to repeat bleeding several times.
Alternate between uphill and downhill parking.

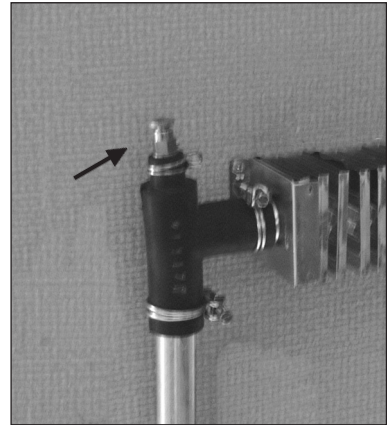

A bleed nipple.

WORKTOP DRAWERS



DRAWER ADJUSTMENT

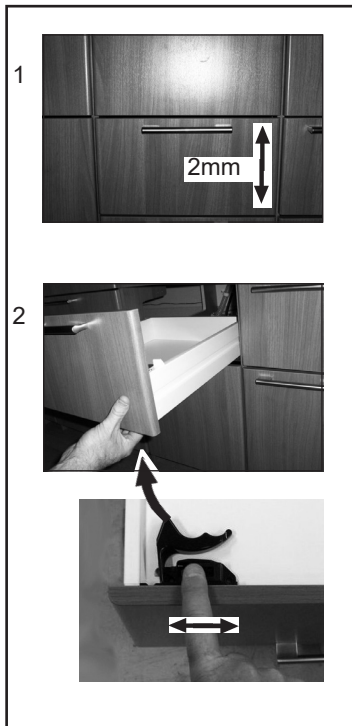

DRAWER REMOVAL

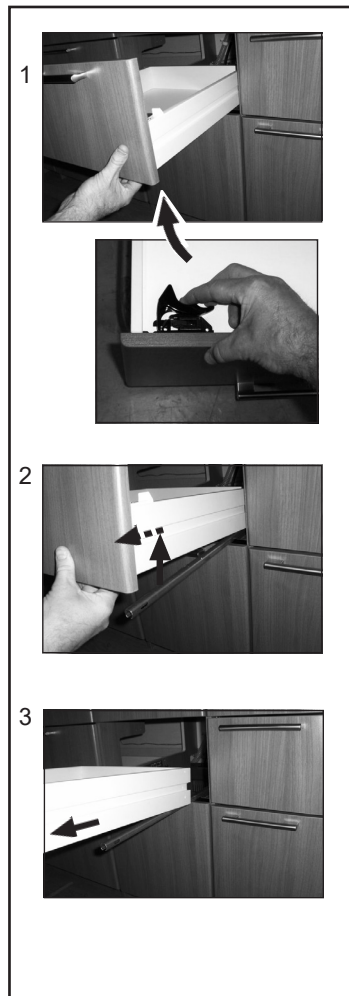

DRAWER FITTING

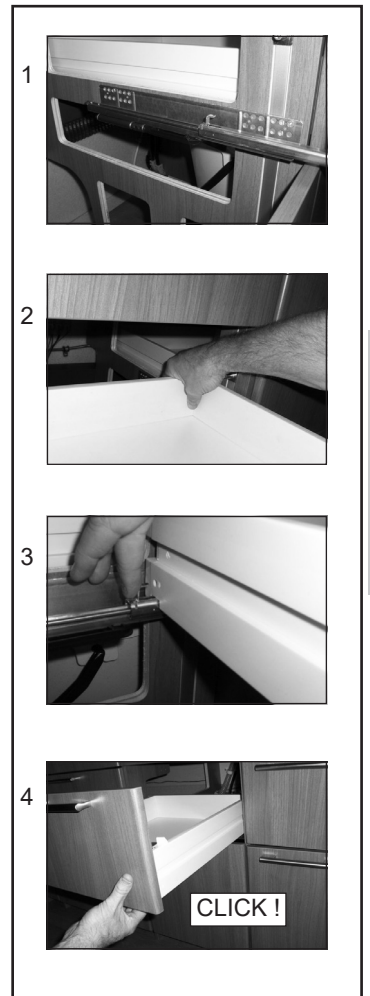

Maintenance

WORKTOP PULL-OUT BASKETS



PULL-OUT REMOVAL



PULL-OUT FITTING

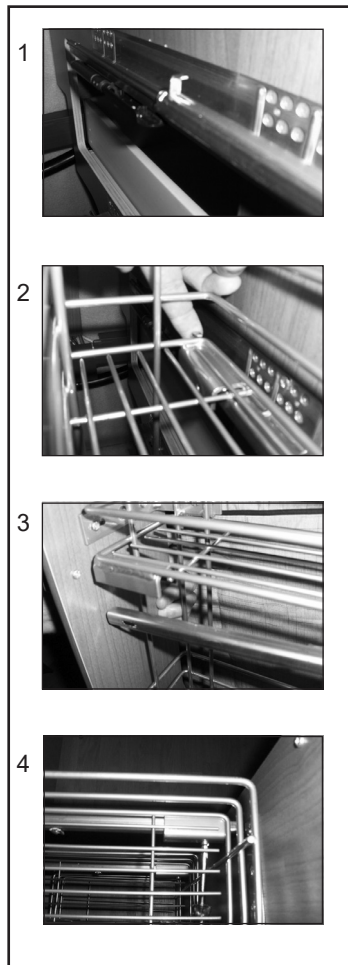

FRONT PANEL ADJUSTMENT

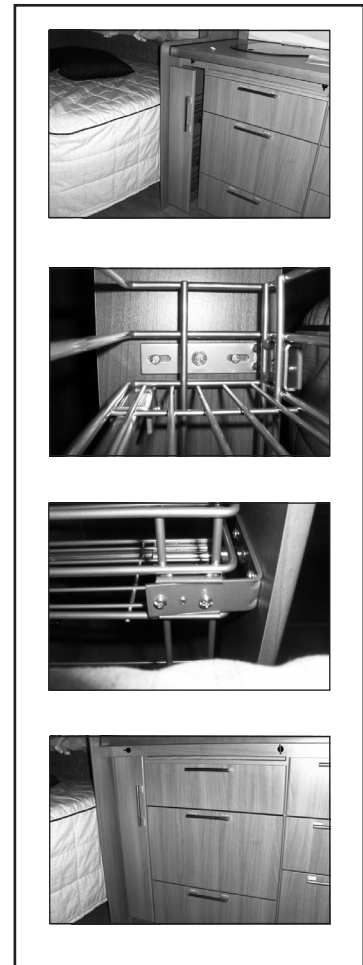

CUPBOARD DOOR ADJUSTMENT

CROCKERY CUPBOARD DOOR

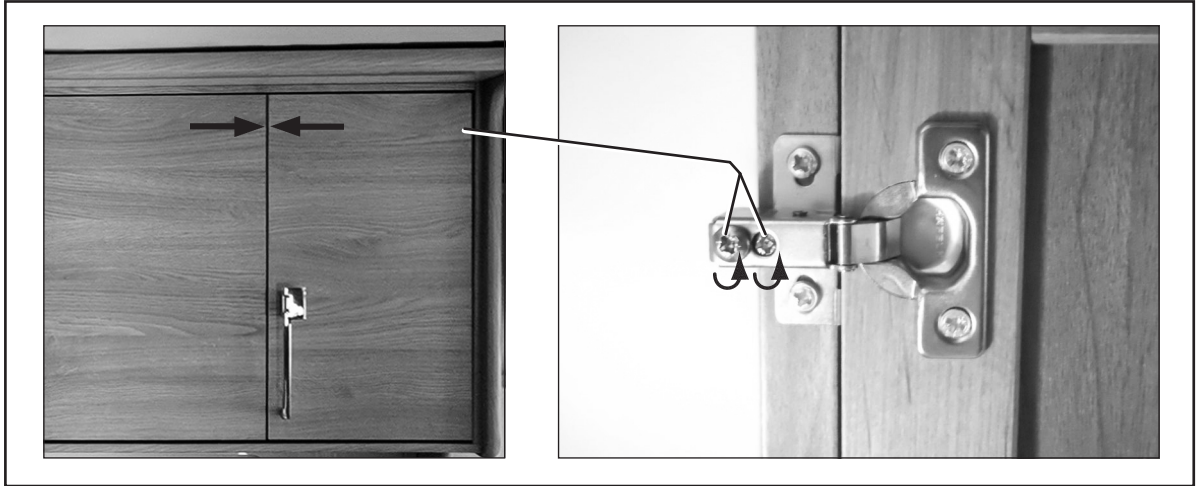

OVERHEAD CUPBOARD DOOR

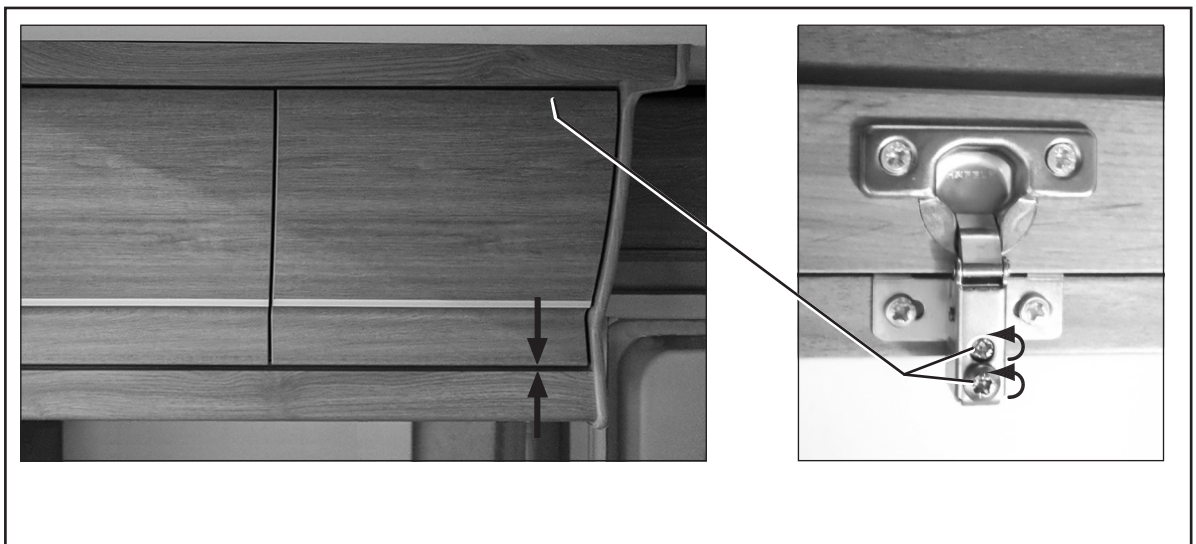

KABE continuously develops all its models. For this reason, please understand that we reserve the right to introduce changes in product design and equipment. These changes may not always be in the user manual. Details, images and descriptions in this user manual cannot be the basis of any claim.

The logo for KABE, featuring the word "KABE" in a bold, red, stylized font with a black outline. The letters are thick and blocky, with a slight shadow effect.

Kabe AB

www.kabe.se

Art.nr: 504916.23 EN